

Grizzly *Industrial, Inc.*®

HEAVY-DUTY SLIDING TABLE SHAPER MODEL G8621 INSTRUCTION MANUAL



COPYRIGHT © 2001 BY GRIZZLY INDUSTRIAL, INC.

**WARNING: NO PORTION OF THIS MANUAL MAY BE REPRODUCED IN ANY SHAPE
OR FORM WITHOUT THE WRITTEN APPROVAL OF GRIZZLY INDUSTRIAL, INC.**

REVISED OCTOBER, 2002. PRINTED IN TAIWAN

ONLINE MANUAL DISCLAIMER

THE INFORMATION IN THIS MANUAL REPRESENTS THE CONFIGURATION OF THE MACHINE AS IT IS CURRENTLY BEING SHIPPED. THE MACHINE CONFIGURATION CAN CHANGE AS PRODUCT IMPROVEMENTS ARE INCORPORATED. IF YOU OWN AN EARLIER VERSION OF THE MACHINE, THIS MANUAL MAY NOT EXACTLY DEPICT YOUR MACHINE. CONTACT CUSTOMER SERVICE IF YOU HAVE ANY QUESTIONS ABOUT DIFFERENCES. PREVIOUS VERSIONS ARE NOT AVAILABLE ONLINE.

WARNING

Some dust created by power sanding, sawing, grinding, drilling, and other construction activities contains chemicals known to the State of California to cause cancer, birth defects or other reproductive harm. Some examples of these chemicals are:

- Lead from lead-based paints.
- Crystalline silica from bricks, cement, and other masonry products.
- Arsenic and chromium from chemically treated lumber.

Your risk from these exposures varies, depending on how often you do this type of work. To reduce your exposure to these chemicals: work in a well ventilated area, and work with approved safety equipment, such as those dust masks that are specially designed to filter out microscopic particles.

Table Of Contents

	PAGE
1. SAFETY	
SAFETY RULES FOR ALL TOOLS	2-3
ADDITIONAL SAFETY INSTRUCTIONS FOR SHAPERS	4
2. CIRCUIT REQUIREMENTS	5
220V OPERATION	5
GROUNDING	5
EXTENSION CORDS	6
WIRING.....	6
3. GENERAL INFORMATION/COMMENTARY	7
UNPACKING	8-9
CLEAN UP	10
SITE CONSIDERATIONS.....	10
4. ASSEMBLY	11
BEGINNING ASSEMBLY	11
HANDWHEEL	11
SPINDLE.....	12
HANDLES	13
GUARD	14
FENCE ASSEMBLY	14-15
GUARD COVER	15
HOLD-DOWNS	16
MITER ASSEMBLY	16-17
5. ADJUSTMENTS	18
PULLEYS & V-BELT.....	18
V-BELT TENSION	19
SPEED CHANGES	19
FENCE ADJUSTMENT.....	20
ALIGNING THE FENCE	20
TABLE INSERTS	21
SETTING MITER GAUGE	21
TEST RUN	22
6. OPERATION	23
ROTATION	23
CUTTER INSTALLATION.....	24
TABLE LOCK	24
SPINDLE HEIGHT	25
STRAIGHT SHAPING	25-26
RUB COLLARS.....	27
PATTERN WORK	28-29
FREEHAND SHAPING	29
MITER ASSEMBLY	29-30
SHAPER ACCESSORIES	30
7. MAINTENANCE	31
GENERAL.....	31
TABLE.....	31
LUBRICATION	31
V-BELT	31
SCHEDULE.....	31
WIRE DIAGRAM.....	32
8. CLOSURE	33
MACHINE DATA.....	34
PARTS BREAKDOWN AND PARTS LISTS	35-41
WARRANTY AND RETURNS	42

SECTION 1: SAFETY

WARNING

For Your Own Safety Read Instruction Manual Before Operating This Equipment

The purpose of safety symbols is to attract your attention to possible hazardous conditions. This manual uses a series of symbols and signal words which are intended to convey the level of importance of the safety messages. The progression of symbols is described below. Remember that safety messages by themselves do not eliminate danger and are not a substitute for proper accident prevention measures.



Indicates an imminently hazardous situation which, if not avoided, WILL result in death or serious injury.



Indicates a potentially hazardous situation which, if not avoided, COULD result in death or serious injury.



Indicates a potentially hazardous situation which, if not avoided, MAY result in minor or moderate injury. It may also be used to alert against unsafe practices.



This symbol is used to alert the user to useful information about proper operation of the equipment.

WARNING

Safety Instructions For Power Tools

1. **KEEP GUARDS IN PLACE** and in working order.
2. **REMOVE ADJUSTING KEYS AND WRENCHES.** Form habit of checking to see that keys and adjusting wrenches are removed from tool before turning on.
3. **KEEP WORK AREA CLEAN.** Cluttered areas and benches invite accidents.
4. **NEVER USE IN DANGEROUS ENVIRONMENT.** Do not use power tools in damp or wet locations, or where any flammable or noxious fumes may exist. Keep work area well lighted.
5. **KEEP CHILDREN AND VISITORS AWAY.** All children and visitors should be kept a safe distance from work area.
6. **MAKE WORKSHOP CHILD PROOF** with padlocks, master switches, or by removing starter keys.
7. **NEVER FORCE TOOL.** It will do the job better and safer at the rate for which it was designed.
8. **USE RIGHT TOOL.** Do not force tool or attachment to do a job for which it was not designed.

⚠️ WARNING

Safety Instructions For Power Tools

9. **USE PROPER EXTENSION CORD.** Make sure your extension cord is in good condition. Conductor size should be in accordance with the chart below. The amperage rating should be listed on the motor or tool nameplate. An undersized cord will cause a drop in line voltage resulting in loss of power and overheating. Your extension cord must also contain a ground wire and plug pin. Always repair or replace extension cords if they become damaged.

Minimum Gauge for Extension Cords

AMP RATING	LENGTH		
	25ft	50ft	100ft
0-6	18	16	16
7-10	18	16	14
11-12	16	16	14
13-16	14	12	12
17-20	12	12	10
21-30	10	10	No

10. **WEAR PROPER APPAREL.** Do not wear loose clothing, gloves, neckties, rings, bracelets, or other jewelry which may get caught in moving parts. Non-slip footwear is recommended. Wear protective hair covering to contain long hair.
11. **ALWAYS USE SAFETY GLASSES.** Also use face or dust mask if cutting operation is dusty. Everyday eyeglasses only have impact resistant lenses, they are NOT safety glasses.
12. **SECURE WORK.** Use clamps or a vise to hold work when practical. It's safer than using your hand and frees both hands to operate tool.
13. **NEVER OVERREACH.** Keep proper footing and balance at all times.
14. **MAINTAIN TOOLS WITH CARE.** Keep tools sharp and clean for best and safest performance. Follow instructions for lubricating and changing accessories.
15. **DISCONNECT TOOLS** before servicing and changing accessories, such as blades, bits, cutters, and the like.
16. **REDUCE THE RISK OF UNINTENTIONAL STARTING.** Make sure switch is in off position before plugging in.
17. **USE RECOMMENDED ACCESSORIES.** Consult the owner's manual for recommended accessories. The use of improper accessories may cause risk of injury.
18. **CHECK DAMAGED PARTS.** Before further use of the tool, a guard or other part that is damaged should be carefully checked to determine that it will operate properly and perform its intended function. Check for alignment of moving parts, binding of moving parts, breakage of parts, mounting, and any other conditions that may affect its operation. A guard or other part that is damaged should be properly repaired or replaced.
19. **NEVER LEAVE TOOL RUNNING UNATTENDED. TURN POWER OFF.** Do not leave tool until it comes to a complete stop.
20. **NEVER USE UNDER THE INFLUENCE** of alcohol or drugs, or when tired.
21. **NEVER ALLOW UNSUPERVISED OR UNTRAINED PERSONNEL TO OPERATE THE MACHINE.** Make sure any instructions you give in regards to the operation of the machine are approved, correct, safe, and clearly understood.

WARNING

Additional Safety Instructions For Shapers

1. **NEVER ALLOW YOUR HANDS** to come within 12 inches of the cutters. Never pass your hands directly over or in front of the cutter.
2. **BLIND CUT WHENEVER POSSIBLE.** This keeps the knives on the underside of the workpiece and provides a distance guard for the operator.
3. **WHEN SHAPING CONTOURED WORK** and using a rub collar, **NEVER** start out at a corner. See the “Rub Collar” instructions further on in the manual.
4. **WITH THE MACHINE UNPLUGGED,** always rotate the spindle by hand with any new setup to ensure proper cutter clearance before starting the machine.
5. **DO NOT SHAPE STOCK SHORTER** than 12 inches without special fixtures or jigs. Where practical, shape longer stock and cut to size.
6. **NEVER ATTEMPT** to remove too much material in one pass. You are far more likely to enjoy safer and higher quality results if you allow the cutter to remove material in multiple passes.
7. **THE DANGER OF** kickback is increased when the stock has knots, holes, or foreign objects in it. Warped stock should be run through a jointer before attempting to run it through a shaper.
8. **KEEP THE UNUSED PORTION** of the cutter below the table surface.
9. **THE USE OF PUSH STICKS** as safety devices in some applications is smart; in others it can be quite dangerous. If the push stick comes in contact with the cutter on the end grain, it can fly out of your hand like a bullet—potentially causing serious injury. We recommend using some type of fixture, jig, or hold-down device as a safer alternative. Always use the guard as described in the manual.
10. **NEVER FORCE MATERIALS** through the shaper. Let the cutters do the work. Excessive force is likely to result in poor cutting results and will cause dangerous kickback conditions.
11. **ALWAYS** ensure that the cutters, fence, and spindle elevator knob have been tightened properly before beginning any operation.
12. **ALWAYS** feed the work toward the cutters in the direction opposite of the cutter rotation. Also, using and maintaining a sharp cutterhead will greatly reduce the chance of kickback.
13. **NEVER REACH BEHIND CUTTER** to grab the workpiece. Your hand may suddenly be pulled into the cutter in the event of a kickback.
14. **IF AT ANY TIME YOU ARE EXPERIENCING DIFFICULTIES PERFORMING THE INTENDED OPERATION, STOP USING THE SHAPER!** Then contact our service department or ask a qualified expert how the operation should be performed.

WARNING

Like all power tools, there is danger associated with shapers. Accidents are frequently caused by lack of familiarity or failure to pay attention. Use this tool with respect and caution to lessen the possibility of operator injury. If normal safety precautions are overlooked or ignored, serious personal injury may occur.

CAUTION

No list of safety guidelines can be complete. Every shop environment is different. Always consider safety first, as it applies to your individual working conditions. Use this and other machinery with caution and respect. Failure to do so could result in serious personal injury, damage to equipment or poor work results.

SECTION 2: CIRCUIT REQUIREMENTS

220V Operation

The Model G8621 Shaper is furnished with a 3450 R.P.M., 5 H.P., Single-Phase 220V motor, push-button ON/OFF magnetic starter switch, forward-reverse switch and a cord set. Under normal use, the motor draws approximately 25 amps @ 220V. We recommend a 30 amp circuit breaker. If frequent circuit failures occur when using the shaper, contact our service department.

The shaper motor must be connected to its own dedicated 30A circuit. The shaper should not share a circuit with any other machine, and the wires in the circuit should be rated for 30A. A standard 2-pole breaker is also necessary for use with the shaper.

We recommend using a NEMA-style L6-30 plug and outlet similar to that in **Figure 1**. You may also “hard-wire” the shaper directly to your panel, provided you place a disconnect near the machine. Check the electrical codes in your area for specifics on wiring requirements.

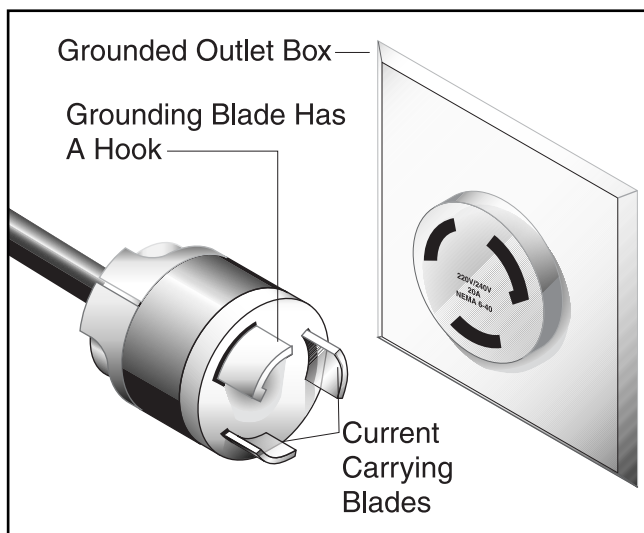

Figure 1. 220V Single-Phase



Grounding

In the event of an electrical short, grounding reduces the risk of electric shock by providing a path of least resistance to disperse electric current. This tool is equipped with an electric cord that has an equipment-grounding conductor which must be properly connected to a grounding plug. The plug must be plugged into a matching outlet that is properly installed and grounded in accordance with all local codes and ordinances.

Improper connections of the electrical-grounding conductor can result in the risk of electric shock. The conductor with green or green and yellow striped insulation is the electrical-grounding conductor. If repair or replacement of the electric cord or plug is necessary, do not connect the equipment grounding conductor to a live terminal.

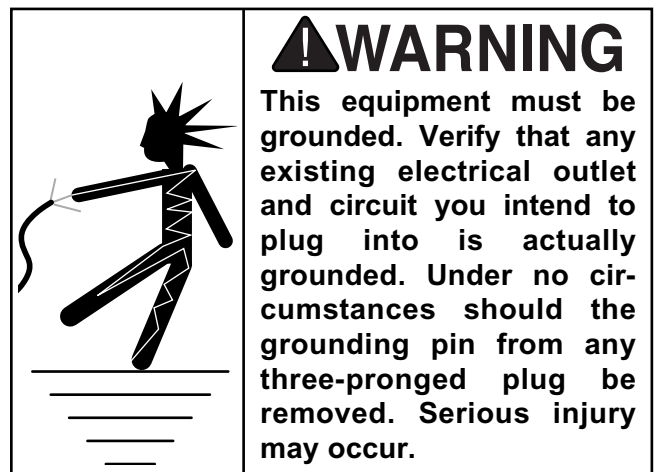

Extension Cords

We do not recommend the use of extension cords on 220V equipment. Arrange the placement of your equipment and the installed wiring to eliminate the need for extension cords. Should it be necessary to use an extension make sure the cord is rated Hard Service (grade S) or better. Refer to the chart in **Section 1: Safety** to determine the minimum gauge for the extension cord. The extension cord must also contain a ground wire and plug pin. Always repair or replace extension cords when they become worn or damaged.



Wiring

A wiring diagram is provided at the back of this manual should it be necessary to repair or revise the wiring. Always utilize a qualified electrician when doing any electrical work on this equipment.

CAUTION

We have covered some basic electrical requirements for the safe operation of your machine. These requirements are not necessarily comprehensive. You must be sure that your particular electrical configuration complies with local and state codes. Ensure compliance by checking with your local municipality or a licensed electrician.



SECTION 3: GENERAL INFORMATION

Commentary

Grizzly Industrial, Inc. is proud to offer the Model G8621 Shaper. This shaper is part of Grizzly's growing family of fine woodworking and metal-working machinery. When used according to the guidelines stated in this manual, you can expect years of trouble-free, enjoyable operation.

The Model G8621 is intended for heavy-duty professional use. The Model G8621 Shaper features a 5 H.P. single-phase motor, offers 220V operation with magnetic power switching and full reversing capabilities. The Model G8621 also features a precision-ground cast iron table, hold-down springs, three interchangeable spindles and a sliding table. This shaper is capable of operating at four spindle speeds: 3600, 5100, 8000 and 10,000 R.P.M., giving you a versatile shaper with plenty of power.

A number of optional accessories for the Model G8621 are available. Please refer to the current Grizzly catalog for more information.

We are also pleased to provide this manual with the Model G8621. It was written to guide you through assembly, review safety considerations, and cover general operating procedures. It represents our latest effort to produce the best documentation possible. If you have any criticisms that you feel we should address in our next printing, please write to us at the address below:

Grizzly Industrial, Inc.
% Technical Documentation
P.O. Box 2069
Bellingham, WA 98227

Most important, we stand behind our machines. We have an excellent service department at your disposal should the need arise. If you have any service questions or parts requests, please call or write to us at the location listed below.

Grizzly Industrial, Inc.
1203 Lycoming Mall Circle
Muncy, PA 17756
Phone:(570) 546-9663
Fax:(800) 438-5901
E-Mail: techsupport@grizzly.com
Web Site: <http://www.grizzly.com>

The specifications, drawings, and photographs illustrated in this manual represent the Model G8621 as supplied when the manual was prepared. However, owing to Grizzly's policy of continuous improvement, changes may be made at any time with no obligation on the part of Grizzly. Whenever possible, though, we send manual updates to all owners of a particular tool or machine. Should you receive one, we urge you to insert the new information with the old and keep it for reference.

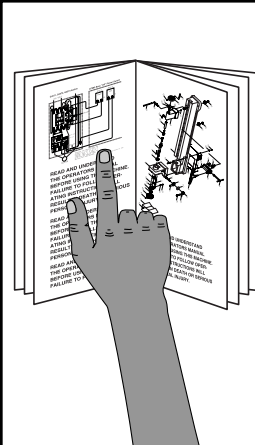
	<p>!WARNING</p> <p>Read the manual before assembly and operation. Become familiar with the machine and its operation before beginning any work. Serious personal injury may result if safety or operational information is not understood or followed.</p>
--	--



Unpacking

The Model G8621 Shaper is shipped from the manufacturer in a carefully packed carton. If you discover the machine is damaged after you've signed for delivery, and the truck and driver are gone, you will need to file a freight claim with the carrier. Save the containers and all packing materials for possible inspection by the carrier or its agent. Without the packing materials, filing a freight claim can be difficult. *If you need assistance determining whether you need to file a freight claim, or with the procedure to file one, please contact our Customer Service.*

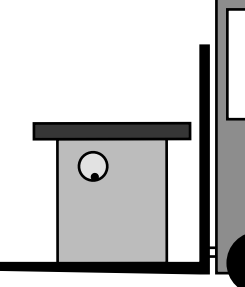

! WARNING

The G7209/10 is a heavy machine, 770 lbs. shipping weight. **DO NOT over-exert yourself while unpacking or moving your machine – you will need assistance and power equipment. Serious personal injury may occur if safe moving methods are not followed.**

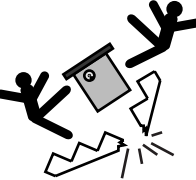

! WARNING

If moving this machine up or down stairs, the machine must be dismantled and moved in smaller pieces. Make sure the stairs are capable of supporting the combined weight of the machine parts and the people moving them.

When you are completely satisfied with the condition of your shipment, you should inventory its parts.

In the event that any nonproprietary parts are missing (e.g. a nut or a washer), we would be glad to replace them, or, for the sake of expediency, replacements can be obtained at your local hardware store.

After all the parts have been removed from the carton, you should have:

- Shaper Unit
- Miter Gauge Kit (**Figure 2**)
- Hardware (**Figure 3**)

The Miter Gauge Kit Hardware and Qty:

1.	Miter Gauge	1
2.	Fence	1
3.	Clamping Unit	1
4.	Support Fence	1
5.	Push Shaft	1
6.	Pointer	1
7.	Washer	1
8.	Bolts	2
9.	Threaded Knob	1
10.	Special Nuts	3
11.	Ratchet Handle	1

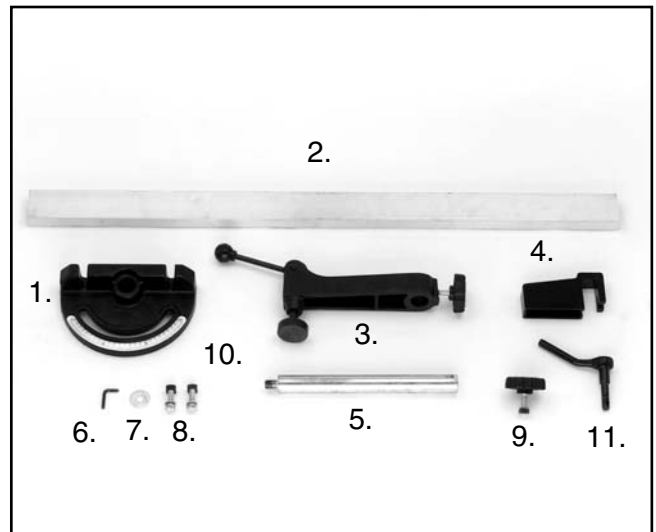

Figure 2. Miter Gauge Kit.

The Model G8621 Hardware and Qty:

3/4" Spindle	1
1" Spindle	1
1 1/4" Spindle	1
3/4" Spindle Nut	2
1" Spindle Nut	2
1 1/4" Spindle Nut	2
Spacer Set	22
Hold Downs	2
Hold Down Bars	2
Hold Down Brackets	2
Fence Pieces	2
Fence Mounts	2
Dust Port	1
Safety Guard	1
Multi Wrench 10, 19, 23, 26, 37mm	1
3mm Allen® Wrench	1
4mm Allen® Wrench	1
1 1/2" Box Wrench	1
1" Box Wrench	1
Stainless Wheel Handles	1
Round Knobs	4
Plastic Adjustment Wheels	2
4 7/8" Threaded Stud Knobs	2
4" Double Threaded-End Bars	2
Draw Bar w/Nut	1
Shaft Guide Bar w/Setscrew	2
Fence-Bracket Ratchet Handles	2
Adjustment Guide Bar	2
5/16" Lock Washers	6
5/16"-18 x 1 5/16" Flat Head Screws	6
5/16" Flat Washers	8
1/2" Flat Washers	4
5/16" Hex Nuts	6



Figure 3. Shaper hardware.



Clean Up

The unpainted surfaces are coated with a waxy oil to protect them from corrosion during shipment. Remove this protective coating with a solvent cleaner or citrus-based degreaser such as Grizzly's G7895 Degreaser. Avoid chlorine-based solvents as they may damage painted surfaces should they come in contact. Always follow the usage instructions on the product you choose to clean.

	<p>! WARNING Do not use gasoline or other petroleum-based solvents to clean with. They have low flash points which make them extremely flammable. A risk of explosion and burning exists if these products are used. Serious personal injury may occur.</p>
---	--

	<p>! WARNING Do not smoke while using solvents. A risk of explosion or fire exists and may result in serious personal injury.</p>
---	--

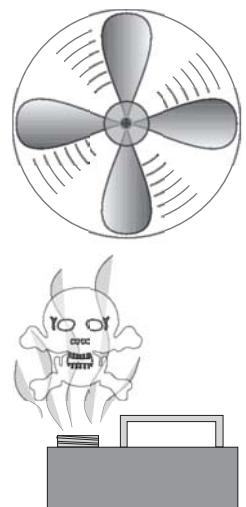
	<p>! CAUTION Many of the solvents commonly used to clean machinery can be toxic when inhaled or ingested. Always work in well-ventilated areas far from potential ignition sources when dealing with solvents. Use care when disposing of waste rags and towels to be sure they do not create fire or environmental hazards.</p>
---	---



Site Considerations

FLOOR LOAD

Your Model G8621 Shaper represents a moderately large weight load in a moderate sized footprint. Most commercial shop floors will be adequate for the 770 lb. weight of the Model G8621. Some floors may require additional support. Contact an architect or structural engineer if you have any question about the ability of your floor to handle the weight.

WORKING CLEARANCES

Working clearances can be thought of as the distances between machines and obstacles that allow safe operation of every machine without limitation. Consider existing and anticipated machine needs, size of material to be processed through each machine, and space for auxiliary stands and/or work tables. Also consider the relative position of each machine to one another for efficient material handling. Be sure to allow yourself sufficient room to safely run your machines in any foreseeable operation.

LIGHTING AND OUTLETS

Lighting should be bright enough to eliminate shadow and prevent eye strain. Electrical circuits should be dedicated or large enough to handle combined motor amp loads. Outlets should be located near each machine so power or extension cords are not obstructing high-traffic areas. Be sure to observe local electrical codes for proper installation of new lighting, outlets, or circuits.

	<p>! CAUTION Make your shop "child safe." Ensure that your workplace is inaccessible to children by closing and locking all entrances when you are away. Never allow visitors in your shop when assembling, adjusting, or operating equipment.</p>
--	---



SECTION 4: ASSEMBLY

Beginning Assembly

Most of your Model G8621 Shaper has been assembled at the factory, but some parts must be assembled or installed after delivery. We have organized the assembly process into steps. Please follow along in the order presented here.

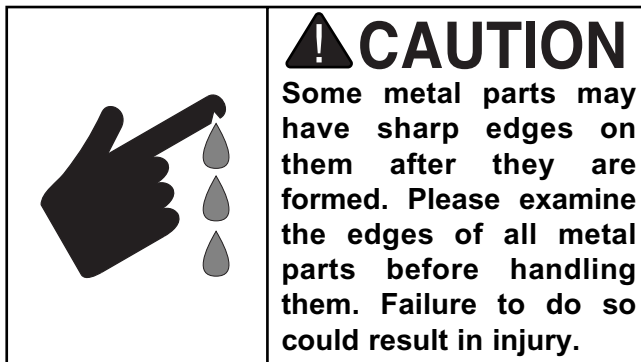
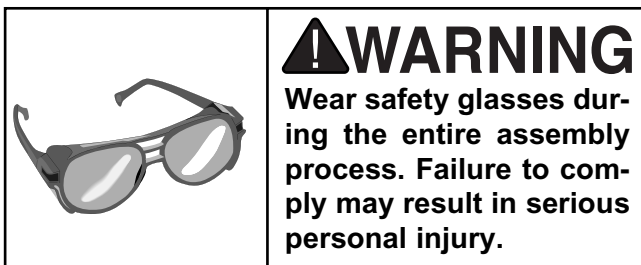

Handwheel

The handwheel, pre-installed at the factory, is made of cast iron. It is used to raise and lower the spindle to accommodate the height required by your cutter.

Thread the crank handle onto the handwheel.



Figure 4. Handwheel mounted to shaper.



Spindle

The Model G8621 comes with three interchangeable spindles like those in **Figure 5**. The spindles must be inserted correctly and remain stable in order to produce quality work. When installing and changing spindles, make sure the spindle seats snugly and that there is enough drawbar threaded into the bottom of the spindle to safely secure it in place. To install a spindle:

1. You should not have your machine connected to a power source at this time. If you do, **UNPLUG** it before you begin.



Figure 5. Spindles.

2. Thread the drawbar approximately 10-15 turns into the bottom of the spindle. The drawbar has two threaded ends. One of them will remain exposed.
3. Drop the spindle/drawbar into the spindle cartridge at the top of the table. Line up the keyway on the spindle with the locating pin at the top of the spindle cartridge. You will feel the spindle seat itself. See **Figure 6**.

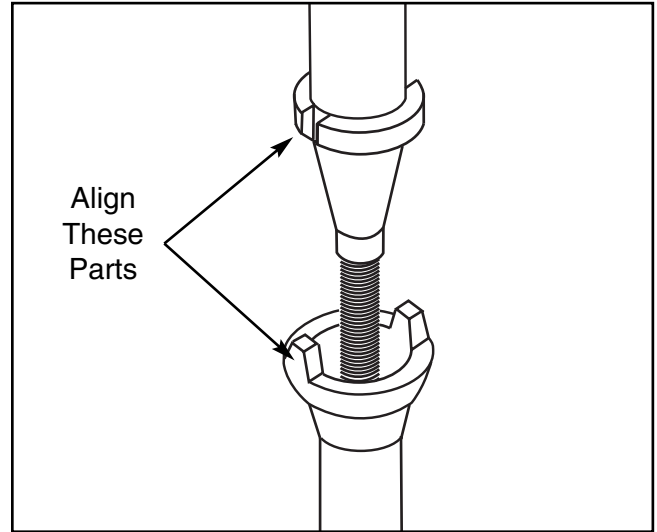

Figure 6. Installing spindle into the cartridge.

4. Thread the drawbar nut, tapered side up, onto the bottom of the drawbar, as illustrated in **Figure 7**.

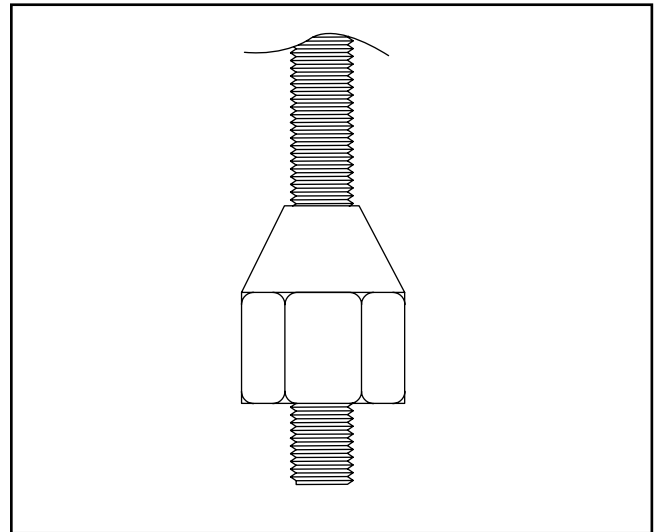

Figure 7. Drawbar nut on spindle.

5. Place the spindle wrench on top of the spindle, so it fits over the head of the spindle. Place a 15mm wrench on the drawbar nut.
6. Hold the spindle in place and tighten the drawbar nut. **DO NOT** use excessive force.



Handles

The guard adjuster is used to secure the guard to the table and to allow the guard to be loosened for adjustment. To assemble the guard adjuster:

1. Install the bar into the shaft guide as shown in **Figure 8**.
2. Line up the groove in the bar with the setscrew.



Figure 8. Slide bar into shaft guide.

3. Tighten the shaft setscrew into the groove to lock the bar in place as shown in **Figure 9**.



Figure 9. Tightening setscrew with hex key.

4. Install the round knobs shown in **Figure 10** onto both ends of the bar.



Figure 10. Thread round knobs onto bar.

The wheel shown in **Figure 11** fits on the adjustment shaft. This locks in place by tightening the setscrew into the groove on the shaft. There is a threaded hole on the wheel that allows for the optional installation of a crank (not included).

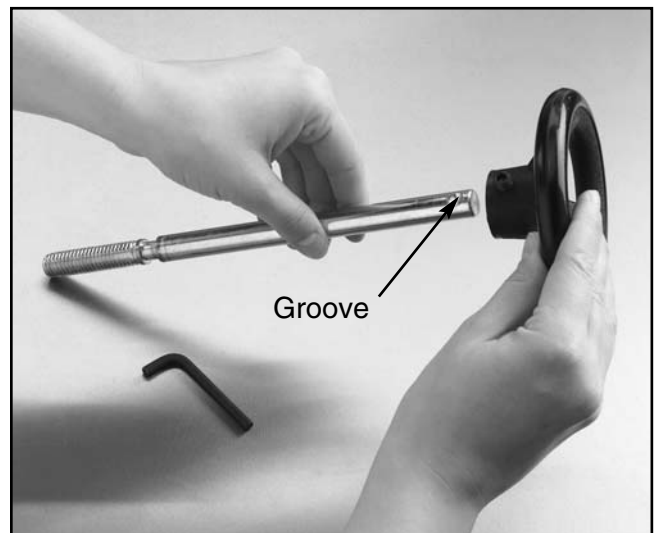

Figure 11. Install wheel onto adjustment guide.



Guard

To mount the cutter guard to the table:

1. Place the guard over the threaded holes on the table.
2. Insert the shaft guide into the guard as shown in **Figure 12**, and thread the shaft guide clockwise to secure the guard to the table.

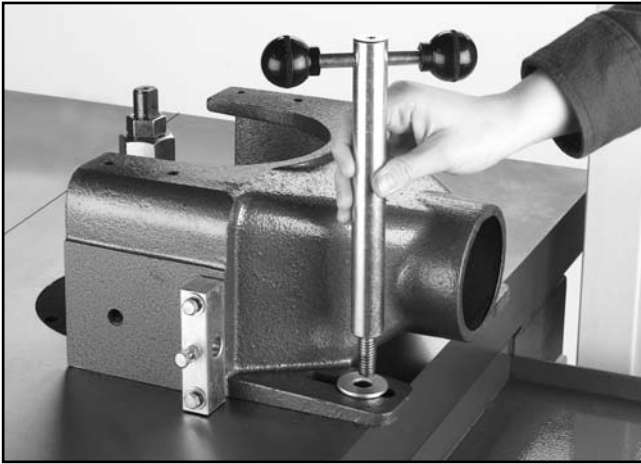

Figure 12. Inserting shaft guide into guard.

Insert the adjustment guide into the screw bracket. Line up the shaft groove shown in **Figure 11** with the center bolt and screw the bolt into the groove as shown in **Figure 13**. Do not completely tighten the bolt. This will allow the shaft to spin without coming out.



Figure 13. Tightening bolt into shaft groove.



Fence Assembly

To mount the fence brackets to the guard body:

1. Insert the adjustment shaft into the fence bracket as shown in **Figure 14**.

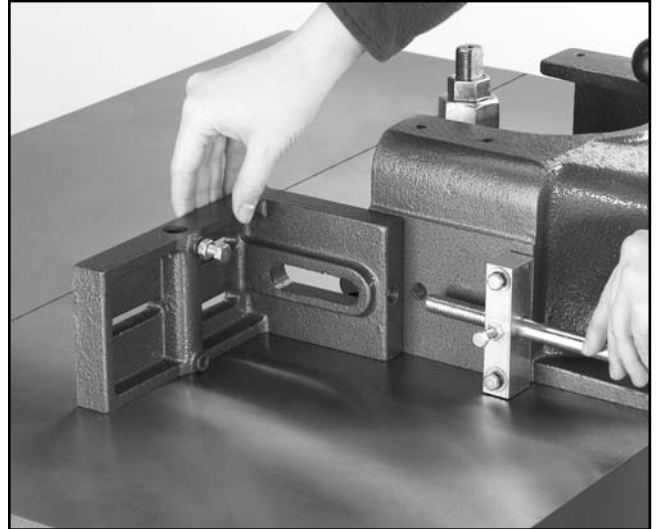

Figure 14. Adjustment guide to fence bracket.

2. Insert the adjustment handle (**Figure 15**) into the fence bracket, and thread it into the guard body.

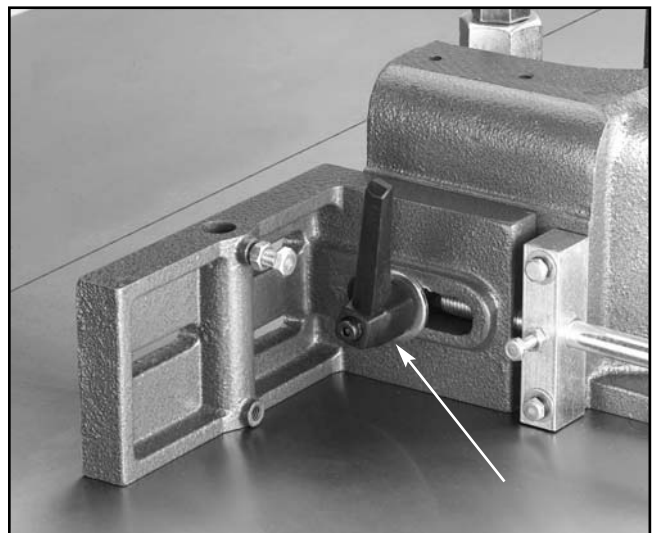

Figure 15. Adjustment handle.

To install the wood facing:

1. Secure the wooden fence pieces (as shown in **Figure 16**) with the $\frac{5}{16}$ "- 18 x 1" Phillips® head screws, washers, and hex nuts provided.
2. If using your own wood faces, make sure the countersunk holes in your fence material are deep enough to keep the entire screw head below the fence surface.



Figure 16. Attach wooden fence assembly.



Guard Cover

To mount the guard cover:

1. Place the guard cover over the threaded holes on top of the guard body as shown in **Figure 17**.
2. Thread the knobs into the guard body and secure the cover.

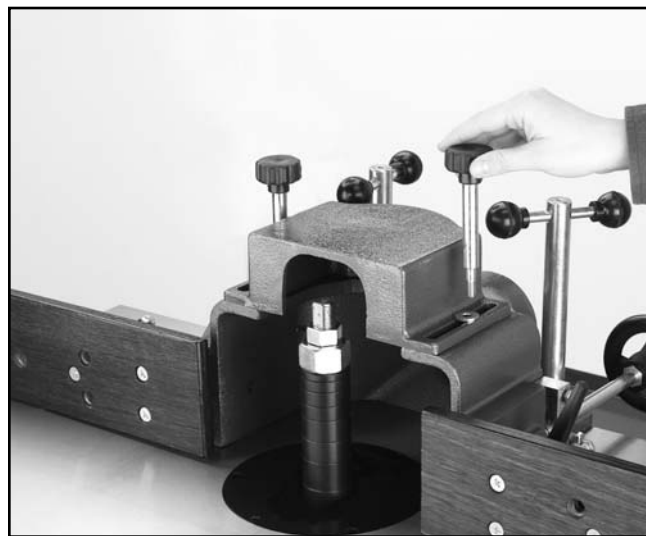

Figure 17. Guard cover.



Hold-Downs

Hold-downs are used to hold the workpiece flat and snug against table as shown in **Figure 18**. To assemble the hold-downs:

1. Slide a hold-down plate into each of the cast iron hold-down brackets.
2. Insert the bracket pole into the fence bracket and hold-down bracket.
3. Partially screw the handle into the hold-down brackets.
4. Position the hold-downs according to the size of your workpiece.
5. Tighten the handles to secure the hold-downs.

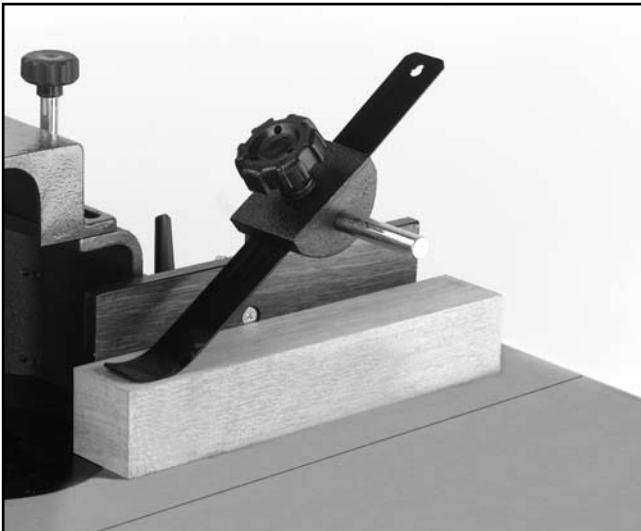

Figure 18. Hold-down on workpiece.



Miter Assembly

The miter gauge for the Model G8621 features a clamp and special fence. The miter gauge assembly can be mounted on either end of the table, depending on the type of desired cut or cutting direction. To mount the miter gauge and its fence:

1. Locate the threaded holes on either side of the table.
2. Install the push shaft as shown in **Figure 19**.



Figure 19. Installing the push shaft.

3. Now, slide the miter gauge down the push shaft as in **Figure 20**.



Figure 20. Installing the miter gauge.

G8621 Heavy-Duty Sliding Table Shaper

4. With the provided washer, thread the ratchet handle through the miter gauge and into the table as shown in **Figure 21**.



Figure 21. Installing the ratchet handle.

5. Insert the the miter gauge pointer shown in **Figure 22**, but do not tighten the nearby setscrew at this time.

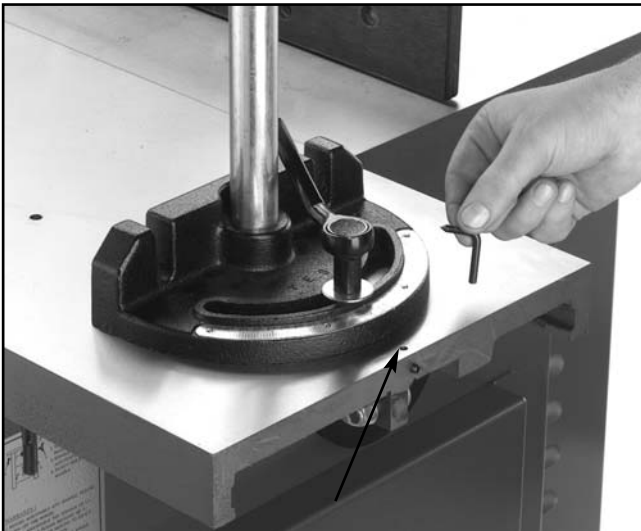

Figure 22. Installing the pointer.

6. Place flat washers on the miter fence hex bolts, then start the special nuts onto the ends. Slide the special nuts into the groove of the fence. The end piece for the fence works with the same special nut and hex bolt system. When these have all been installed on the miter fence, it is time to install the fence onto the miter gauge as in **Figure 23**.



Figure 23. Installing the miter fence.

7. Slide the clamping unit onto the push shaft as shown in **Figure 24**.



Figure 24. Installing the clamping unit.



SECTION 5: ADJUSTMENTS

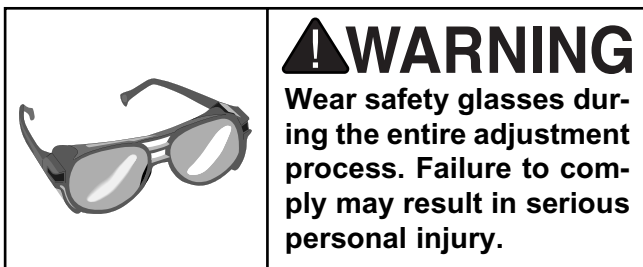
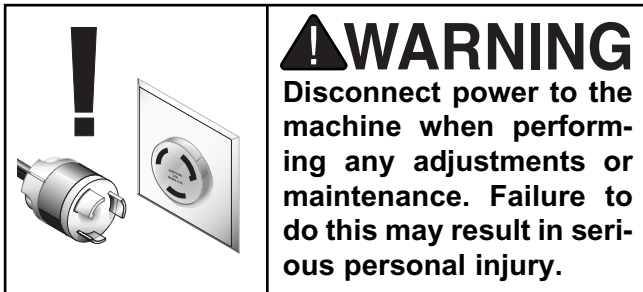

Pulleys & V-Belt

Improper pulley alignment sharply reduces the effectiveness of power transmission and belt life expectancy. To align the pulleys:

1. Remove the motor cover from the back of the shaper cabinet to expose the motor and pulleys.
2. Check the alignment with a straightedge. If the pulleys are in alignment, the straightedge should touch two sides of each pulley evenly as in **Figure 25**.
3. If the pulleys are parallel with each other, but not in-line, the motor needs to be adjusted.

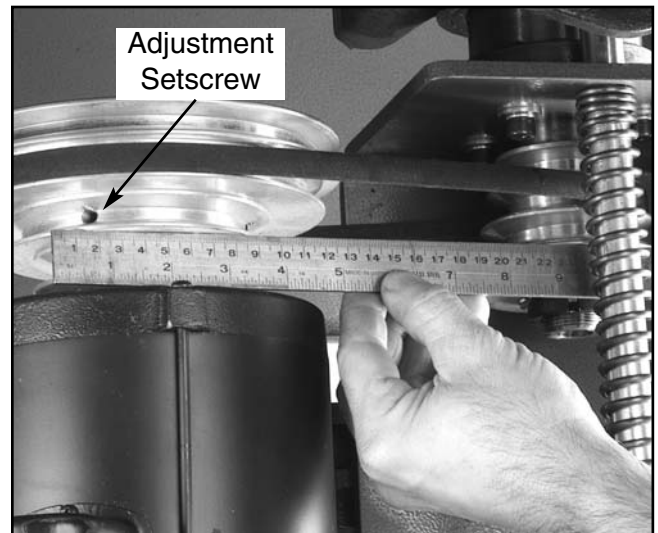

Figure 25. Inspecting pulley alignment.

4. This process is easiest with the help of another person. Loosen the four bolts that attach the motor to the motor base. One person should slide the motor either up or down while the other person measures the alignment of the motor pulley and the spindle pulley with a straightedge.
5. When the motor pulley and the spindle pulley alignment are correct, tighten the motor to the motor base.
6. Inspect your results. If satisfactory, double-check that the mounting bolts are tight.
7. You can also make small adjustments in the motor pulley alignment by raising or lowering it along the motor shaft. To do this, loosen the two setscrews (one is shown in **Figure 25**) which are in the lowest groove of the motor pulley and move the pulley into position. Tighten the setscrews when the alignment is satisfactory.



V-Belt Tension

You should be able to deflect the belt $\frac{1}{4}$ " with moderate finger pressure. This may seem tight compared to most other V-belts, but since the belt is small and runs fast, this amount of tension is necessary. The V-belt will slip if too loose, and will squeal or cause vibration if too tight. Adjust the tension if necessary. To adjust V-belt tension:

1. Make sure the pulleys are properly aligned.
2. Loosen the two motor mount plate bolts and slide the motor left or right to modify the belt tension. Keep the pulleys aligned.
3. Tighten the motor mount plate bolts, test the tension, and check the pulleys.
4. Repeat **steps 2-3** until tension is correct and the pulleys are aligned.



Speed Changes

The Model G8621 Shaper is equipped with a V-belt drive system that controls the speeds. To change spindle speeds:

1. Unplug the machine.
2. Loosen the two motor plate bolts, and slide the motor toward the spindle assembly. **DO NOT** take the bolts out.
3. Select the desired speed. There are four speeds: 3600 R.P.M., 5100 R.P.M., 8000 R.P.M., 10,000 R.P.M. **Figure 26** shows the belt positions for each available speed.

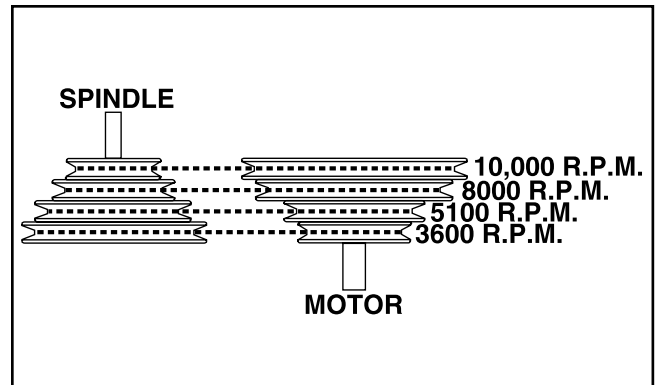

Figure 26. Spindle speed adjustment.

4. Align the belt along the appropriate pulley grooves.
5. Slide the motor back into position and tighten the belt. When the belt is properly tensioned, there should be approximately $\frac{1}{4}$ " of deflection in the center of the belt when you press it with moderate pressure.
6. Tighten all the adjusting bolts.
7. Spin the pulley to ensure proper tracking.



Fence Adjustment

The fence is a two-piece adjusting system. Each fence is independently adjustable to compensate for different cutting thicknesses and special shaping applications. Without any play, one turn of the knob moves the split fence approximately $\frac{5}{64}$ " (.078"). To adjust the fence:

1. Loosen the fence lock handle.
2. Turn the fence adjustment knob until the fence is set to the desired position.
3. Tighten the fence lock handle.

More detailed information concerning fence adjustments is covered in the "Straight Shaping" instructions.



Aligning The Fences

The following procedure ensures that the fence is parallel with itself and square with the table.

1. Check that the bolts through the wood facing are tight on each side and are adequately countersunk.
2. To align the wood facing, adjust one or both fence halves so they are in close alignment. Micro-adjust and check the alignment with a straightedge as shown in **Figure 27**.
3. If the wood fences are not parallel with each other, shim the incorrect side with electrical washers. Normal washers may work, but electrical washers allow for fine adjustments.

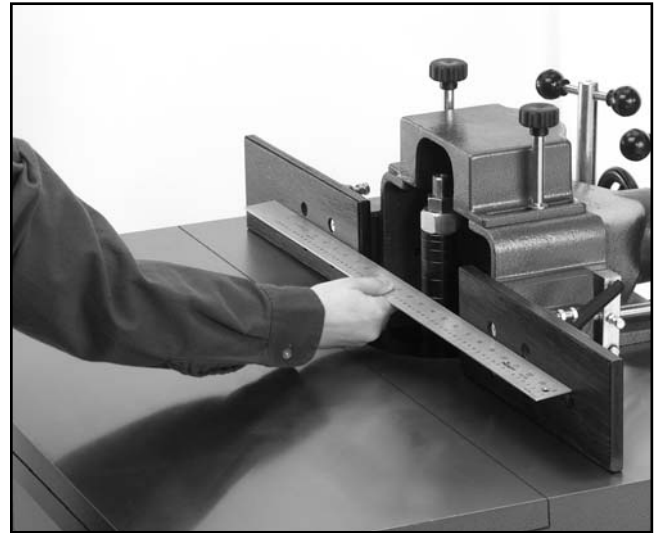

Figure 27. Aligning fences with straightedge.



Table Inserts

The Model G8621 is supplied with two inserts which provide three possible opening diameters in the shaper table surface. Use the smallest opening that a particular cutter will allow. This offers more support for the workpiece and reduces the amount of chips that can fall into the machine. The correct spindle opening also allows any unused portion of the cutter to remain below the table surface—increasing operator protection.

The cast iron table insert must be flush with the top of the table. To adjust the insert:

1. Remove the three Phillips® head screws that hold the cast iron insert in place.
2. By using a straightedge and a screwdriver, turn the barrel screws clockwise or counter-clockwise to level the cast iron insert with the table. **See Figure 28.**

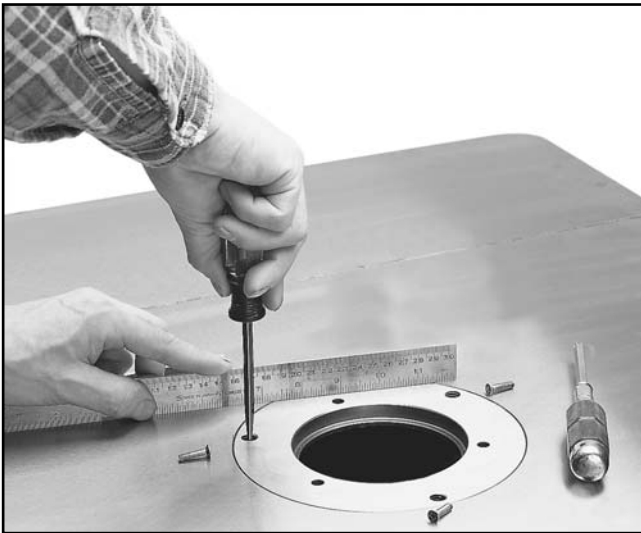

Figure 28. Leveling table insert.

3. Inspect with the straightedge from both side-to-side and front-to-back to ensure the insert is flush with the table. Replace and secure the Phillips® head screws.



Setting Miter Gauge

It is necessary to square the miter gauge each time it is removed from the table. To do this:

1. Ensure that the fence halves are aligned and that the miter assembly is correctly assembled.
2. Place one end of a framing or try square flush with the infeed shaper fence.
3. Rotate the miter gauge so that it lines up flush with the other end of the square.
4. Set the miter gauge pointer to 0° and tighten the setscrew as shown in **Figure 29.**



Figure 29. Setting the miter gauge pointer.

5. Keeping the square flush with the infeed fence and the miter fence, clamp it to the table, and slide the table across the shaper. The square should stay flush with both infeed and outfeed fences during this movement. If this is the case, proceed to the next section. If they do not stay flush or are not square to the miter fence, repeat **steps 1-4** until they are true.



Test Run

Once assembly is complete and adjustments are done to your satisfaction, you are ready to start the machine.

DO NOT have a cutter installed when you test run the shaper. Turn on the power supply at the main panel. Press the *ON* button. Make sure that your finger is poised on the *OFF* button, just in case there is a problem. The shaper should run smoothly with little or no vibration or rubbing noises. Strange or unnatural noises should be investigated and corrected before operating the machine further.

If the shaper seems to be running correctly, check the directional switch. The spindle should be rotating in a counterclockwise direction when the switch is in the *FWD* position. Run the Model G8621 for a short time to ensure that the moving parts are working properly with no excessive vibration. If any problem develops, correct it before attempting to use the machine.

If you cannot locate the source of unusual noises, immediately contact our service department for help.

	<p>! WARNING Disconnect power to the machine when performing any adjustments or maintenance. Failure to do this may result in serious personal injury.</p>
--	---

<p>! WARNING Never use the Model G8621 for applications other than those for which it was intended. DO NOT overload the machine or use excessive force when shaping materials. Severe personal injury, damage to the machine, or damage to your workpiece could occur.</p>
--



SECTION 6: OPERATIONS

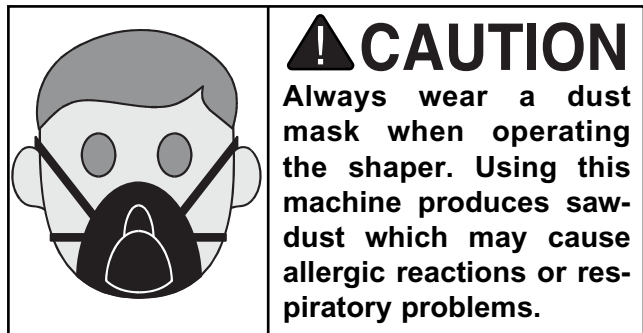
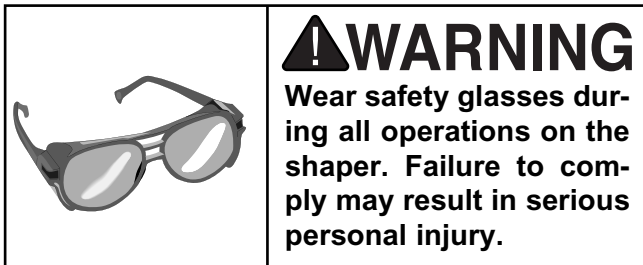

NOTICE

The following section was designed to give instructions on the basic operations of this shaper. However, it is in no way comprehensive of every shaper application. There are many different jigs that can be built to increase safety, accuracy, and types of cuts. **WE STRONGLY RECOMMEND** that you read books, trade magazines, or get formal training to maximize the potential of your shaper.

Rotation

Your shaper is equipped with a FORWARD/REVERSE switch as shown in **Figure 30**. In many instances, you will need to flip the cutter over and reverse cutter rotation. Whenever possible, mount the cutter so the board is milled on the bottom side. This method does a better job and is safer for the operator.

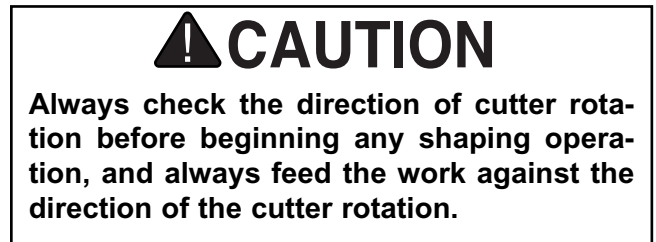

Figure 30. FORWARD/REVERSE switch.

NOTICE

This machine was designed to be started and stopped with the **ON/OFF** buttons—not the reversing switch.



Cutter Installation

Your shaper operates at speeds of 3600, 5100, 8000 and 10,000 R.P.M. 3½" or larger cutters must be operated at the slowest speed.

Always use the largest spindle size possible, and never use more than one bushing size to gain two spindle sizes. "Stacking" two cutter bushings to decrease the inside diameter of the cutter will cause the cutter to perform incorrectly when placed under a load.

1. Unplug the shaper.
2. Place an appropriate spacer or collar at the base of the spindle for support. Place the cutter on the spindle, making sure the rotation is correct for your application.
3. Use spacers or collars to suit your particular application, then place the spindle washer under the nut. Screw on the nut and locknut.
4. Tighten the nuts while holding the spindle stationary. Use a wrench on the notches at the top of the spindle for leverage as shown in **Figure 31**.



Figure 31. Tightening spindle nuts.

!WARNING

Always use a spindle lock nut during operation. If this warning is ignored, the cutter may fly off the spindle during use and cause severe personal injury.



Table Lock

The sliding table works with the clamping miter gauge to allow you to secure your workpiece to the table and make the cut by sliding the table. This feature greatly increases operator safety because it keeps hands away from the cutter-head.

When the sliding operation is not desired, the table lock shown in **Figure 32** will make the table stationary. Simply pull the knurled shaft and twist it so the cross pins slide into the largest slots in the housing. If you want to unlock the table, pull the shaft, twist it, and place the cross pins in the smallest slot.

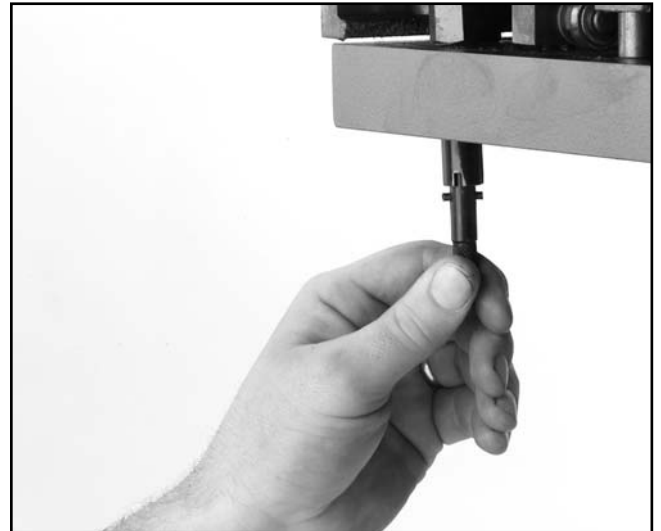

Figure 32. Table lock.

!CAUTION

The sliding table makes it easy to feed the work into the cutter at a faster rate than would normally be used. Always feed the work slow and steady to avoid kickback and to achieve smooth results with your work. Although the miter assembly does aid in safety, common sense should always be used during every shaping operation.

Spindle Height

To adjust the cutter height:

1. Loosen the spindle lock shown in **Figure 33**.
2. Move the spindle up or down with the hand-wheel until the desired position is obtained.
3. Lock the spindle into position.



Figure 33. Location of spindle lock.

NOTICE

The lock knob keeps the spindle in a fixed position during shaper operation. Do not over-tighten the lock knob. A snug fit is all that is needed to keep the spindle from moving during shaper operation.

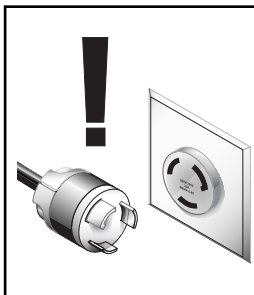

! WARNING

Disconnect power to the machine when performing any adjustments or maintenance. Failure to do this may result in serious personal injury.



Straight Shaping

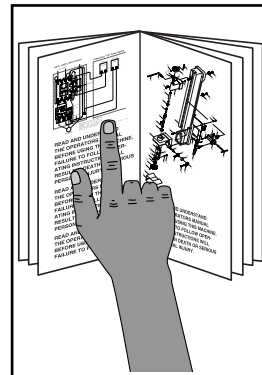

! WARNING

Read the entire manual before making any cuts with your shaper. Serious personal injury may result if safety or operational information is not understood or followed.

The fence assembly is a two-piece, independently adjustable system. When removing material from the whole face of your workpiece, the outfeed fence can be adjusted to provide support for the workpiece as it passes over the cutter. The outfeed fence can also be set in-line for partial face removal.

If removing material from the whole face, observe the following steps:

1. Loosen the locking handles shown in **Figure 34** that hold the fences in place.

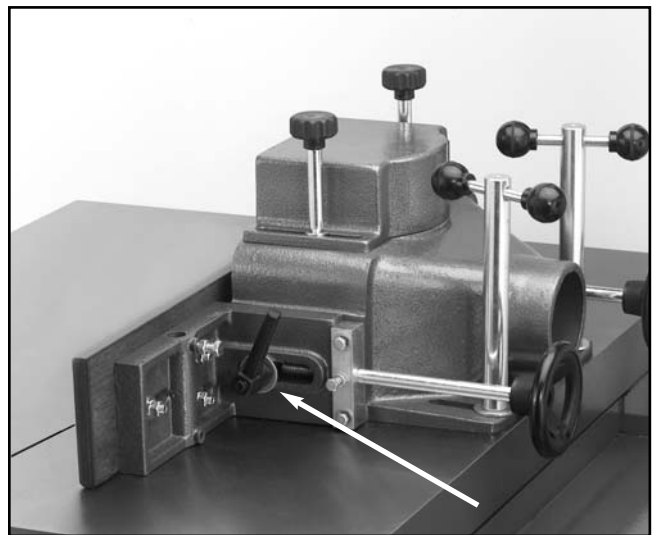

Figure 34. Location of fence locking handles.

2. Adjust the infeed fence by turning the adjustment knobs until the workpiece contacts the cutter in the desired location.
3. Lock the infeed fence in position with the locking handle. Use a test piece to determine the best setting.

4. Loosen the mounting screws on the fence faces and set the face ends to barely clear the cutter. This allows the maximum support possible for the workpiece while passing the cutter. Remember to tighten the wood facing before starting the shaper.
5. A test sample of the desired cut should be advanced about 8" then stopped.
6. Once the shaper is turned off and the cutter has come to a complete stop, adjust the out-feed fence to support the new profiled edge. **See Figure 35.**

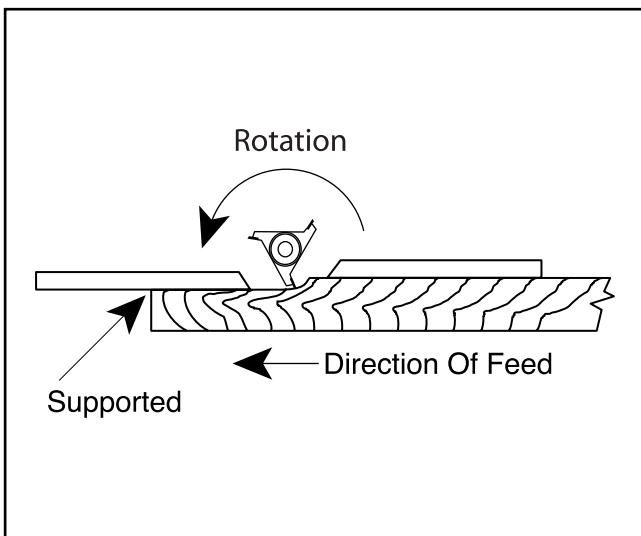

Figure 35. Fence adjusted to support workpiece.

If the face of the workpiece will only be partially removed, observe the following steps:

1. Adjust the infeed fence to approximately the desired depth of cut. Lock the infeed fence in place.
2. Use a straightedge to adjust the outfeed fence to the same plane as the infeed. Lock the outfeed fence in place.
3. Set the right and left wood face ends so they barely clear the cutter. This allows the maximum support possible for the workpiece while passing the cutter. Remember to tighten down the wood facing before starting the shaper.

4. Run a test piece through the shaper as shown in **Figure 36.**

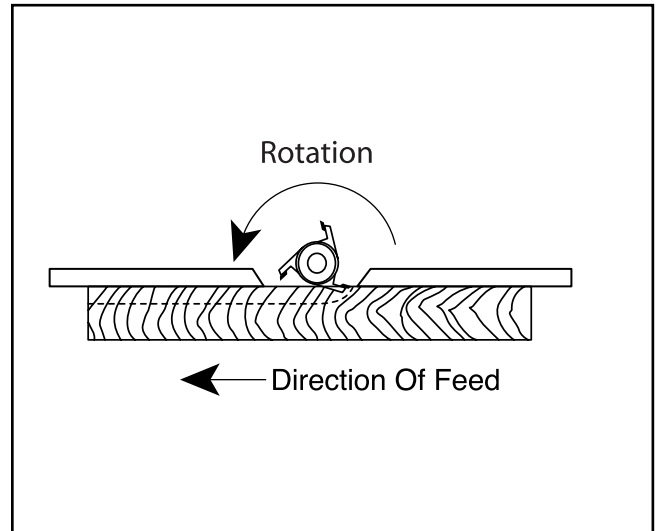

Figure 36. Fence adjustment for blind cuts.

5. Always cut the end grain first when putting an edge around the perimeter of your workpiece. **See Figure 37.**

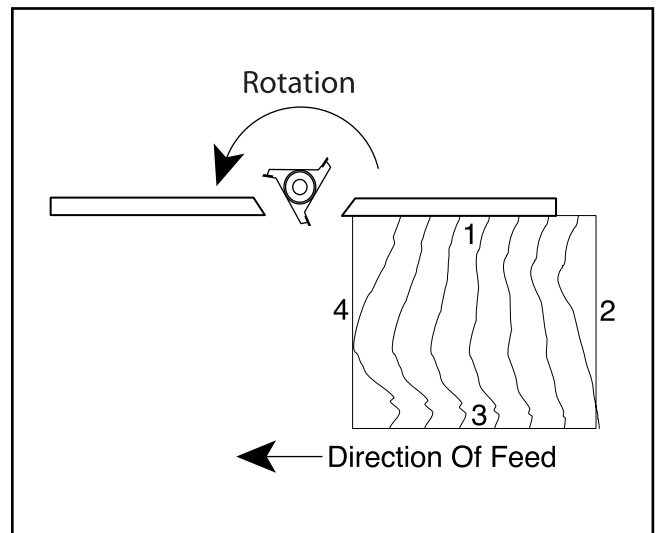

Figure 37. Sequence for multiple cuts.



Rub Collars

Rub collars are used when shaping curved or irregular workpieces, such as arched doors or round table tops. Rub collars also limit the depth of your cut.

There are two types of rub collars—solid and ball-bearing. We recommend against the use of solid rub collars. Grizzly carries an extensive line of ball bearing rub collars designed for use with Grizzly shapers. See the current catalog for listings.

Rub collars may be used in any of the following positions:

1. **Rub collar below the cutter:** When the rub collar is used below the cutter as shown in **Figure 38**, the progress of the cut can be observed. However, any unintentional movement may lift the workpiece into the cutter, damaging your work and creating a dangerous situation that may result in kickback. We do not recommend using the rub collar below the cutter.

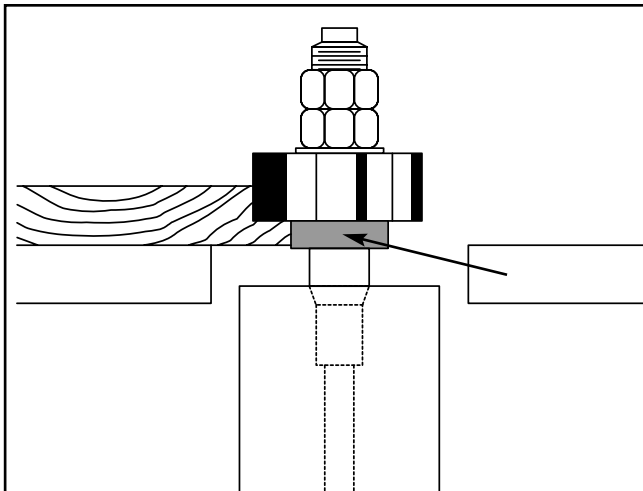

Figure 38. Rub collar installed below cutter.

CAUTION

Whenever the cutterhead is above the workpiece, or you can see it spinning during use, you must take extreme caution to keep your hands away from the cutterhead. Failure to do so may cause serious personal injury.

2. **Above the cutter:** When the rub collar is used above the cutter as seen in **Figure 39**, the cut cannot be seen. This offers some advantage: the stock is not affected by slight variations in thickness and accidental lifting will not damage the workpiece. If lifting occurs, simply correct the mistake by repeating the operation.

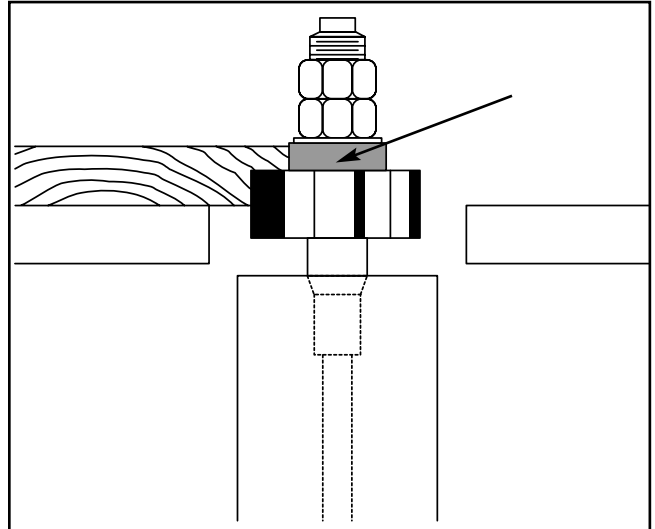

Figure 39. Rub collar installed above cutter.

3. **Between two cutters:** Using a rub collar between two cutters, as in **Figure 40**, has the distinct advantage of performing two cuts at once or eliminating the need to change cutters for two different operations. Notice that part of the edge is left uncut. The uncut portion rides on the rub collar.

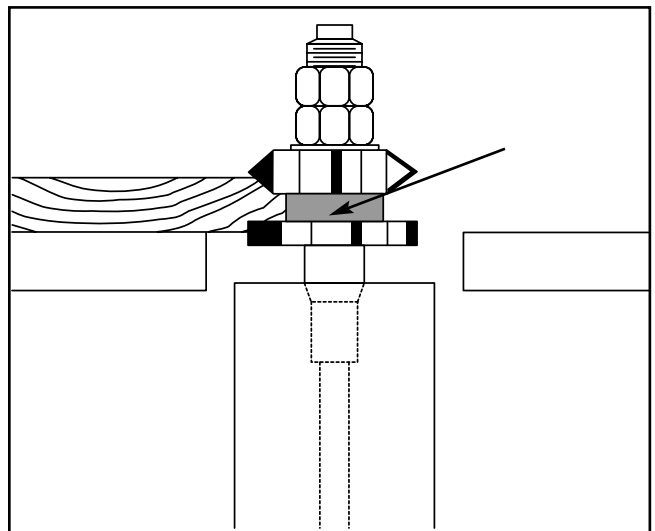

Figure 40. Rub collar between two cutters.



Pattern Work

When using a pattern, the rub collar can be positioned either above, below or between cutters.

The pattern is usually used when the entire edge is to be shaped or when many duplicate pieces are needed. Pattern work is particularly useful when rough cutting irregular or oversize pieces and then shaping the edge in a simple two-step operation. A pattern can be incorporated into a jig by way of adding toggle clamps, hand holds or other safety devices.

You have greater flexibility when choosing the correct diameter rub collar for pattern work than for non-pattern work. If you look at **Figure 41**, you will notice that the position of the pattern determines the depth of cut. In other words, your pattern size is dependent upon the interrelationship of the cutting circle, the desired amount of material removed, and the rub collar size. Changing one or more of these will change the amount of material removed. Planning ahead, you can most effectively decide which rub collars are best suited for your application.

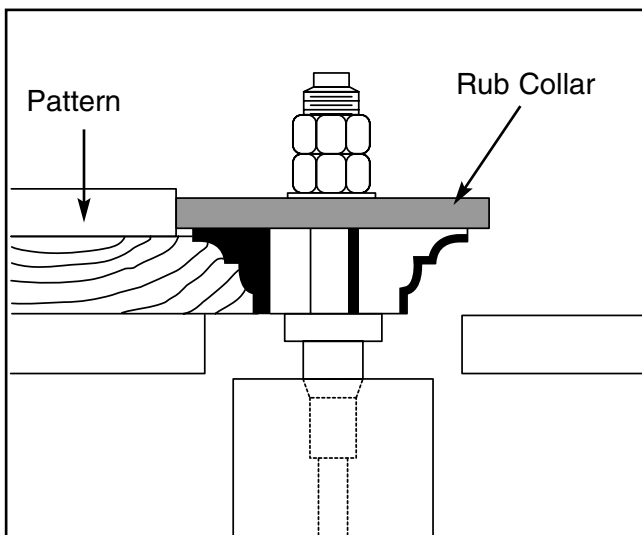

Figure 41. Rub collar determines depth of cut.

When making a pattern jig here are a few things to consider:

1. Build your jig from a material that will smoothly follow the rub collar or fence.

2. Make the jig stable, using proven methods and materials, and fasten the hand holds for operator comfort and safety.
3. Secure your workpiece on the three sides that will not be cut with toggle clamps, or fasten the workpiece to the jig with wood screws.
4. Ensure that clamps and hidden screws do not come into contact with the cutter.
5. Design your jig so that all cutting occurs underneath the workpiece as shown in **Figure 42**. Notice the operator is not exposed to the cutting edge of the cutter!
6. Always consider the cutting circle and rub collar diameter for the correct cutting depth when designing your pattern.
7. Make sure the workpiece rests flat on the table, not on the fixture.

CAUTION

Workpieces must be solid, stable, and secured to the jig; or kickback may occur, causing personal injury.



Figure 42. Pattern jig for making curved pieces.

Irregular or freehand shaping takes a high degree of skill and dexterity. The fence assembly is not used during irregular shaping, so rub collars must be used. Also, unless your jig is designed to touch the rub collar before contacting the blade, a starting fixture must be used to begin your cut.

About starting fixtures:

The purpose of the starting fixture is to support the workpiece during the beginning of the cut. The workpiece is typically placed in the starting position using the starting fixture for support. Then swung into the cutter while holding the workpiece firmly against the starting fixture. After the cut has been started, the work is swung away from the starting fixture and is supported only by the rub collar. **Always feed against the rotation of the cutter and do not start cuts at corners.**

To use your pattern jig:

1. Remove the fence assembly. Choose the appropriate cutter and rub collar for your application and lock them in place. Secure your workpiece to the pattern jig.
2. Check cutter rotation, and adjust the spindle height to align the cutter to your workpiece. Clamp a starting fixture to the table surface, using the location that best supports your work.
3. If everything is correct and the cutter is tight. Turn the shaper on.
4. Place your jig/workpiece against the starting fixture. Using firm pressure, pivot the workpiece into the cutter and make sure the jig is touching the rub collar. Keep your jig in contact with the rub collar and slowly follow the pattern, moving against the cutter rotation.



Freehand Shaping

Freehand methods are one of the most dangerous operations performed on a shaper. Although this machine is capable of performing freehand operations, we do not recommend that you attempt to do so. If you **MUST** perform freehand operations, get formal training and read a book that details freehand operations, their inherent dangers, and ways to avoid those dangers!



Miter Assembly

When the workpiece is clamped to the table using the miter assembly, crosscuts can be made with a much greater degree of safety. The miter gauge can be adjusted to 60° in both directions. **Figure 43** shows the miter gauge set to 0° and **Figure 44** shows it at 45°. To adjust the miter fence:

1. Loosen the miter gauge with the adjustment handle.
2. Assuming that you have performed the steps in the “Setting Miter Gauge” instructions, turn the miter gauge in the desired direction so the pointer indicates the angle, and tighten the miter gauge with the adjustment handle.

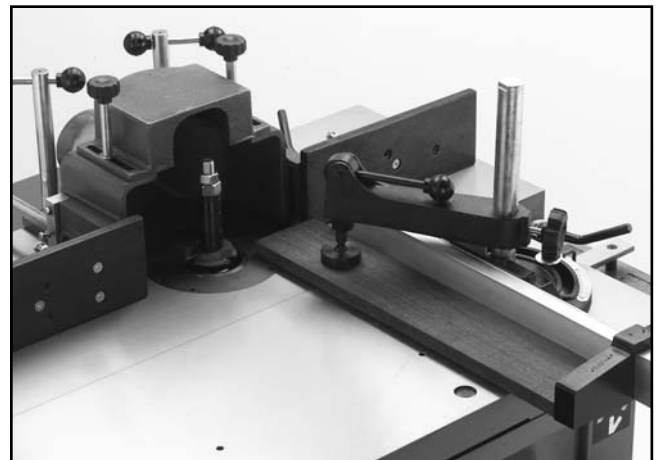

Figure 43. Miter gauge set to 0° (fences opened for clarity).

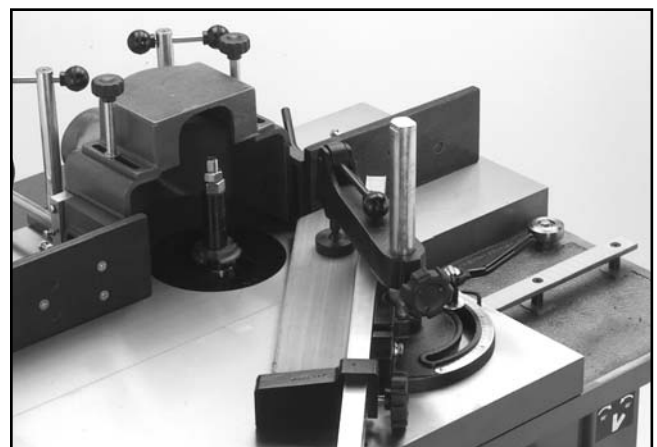

Figure 44. Miter gauge set to 45° (fences opened for clarity).

Shaper Accessories

The **miter fence** can be adjusted by loosening the two bolts that hold it to the miter gauge and then sliding it in the desired direction.

The **support fence** slides up and down the miter fence and can be locked to hold the back of the workpiece in place.

The **miter clamp** holds the workpiece firm against the table and keeps it in position against all of the associated fences.

To use the miter assembly:

1. Determine the angle of cut and set the miter gauge to that angle, without tightening it yet. (The angle of the miter gauge should be determined by the angle of the workpiece you are about to shape.) Lock the miter gauge in place.
2. Move the infeed and outfeed fences out of the way. Hold the workpiece flush against the miter fence and slide the workpiece and table toward the cutter. Line the workpiece up with the cutter.
3. Slide the support fence to the back of the workpiece and lock in place.
4. Clamp the workpiece to the table with the miter clamp as shown in **Figure 45**.
5. The workpiece is now ready for the cut.

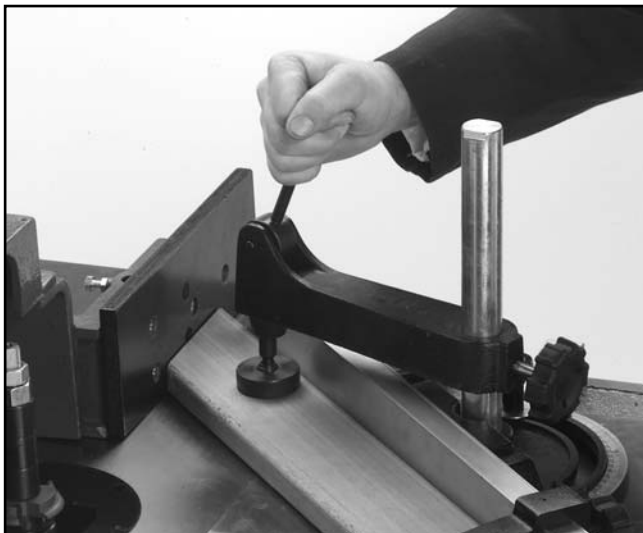

Figure 45. Locking down the miter clamp.

There are many accessories that can be built or purchased to increase the safety of the operator. Many experienced shaper users regularly use proven shop-made fences and safety guards to augment their shaping operations. In addition, many production shops routinely use power feeders with their shapers to streamline their operations.

Here are some basic accessories and their uses:

- **Zero Clearance Fence** — A shop-made fence with an opening only as large as the cutter, so that only the part of the cutter being used is exposed.
- **Box Fence** — A shop-made box that completely surrounds the cutter. A one-piece fence is attached that allows only the thickness of the board to pass underneath, thereby completely shielding the operator from exposure to the spinning cutter. A clear plexiglass window on top of the box allows the operator to view the workpiece during cutting.
- **Power Feeder** — A motorized unit that can be clamped or permanently mounted to the table of a shaper. A power feeder pulls the workpiece through the cut, reducing the risk of operator contact with the spinning cutter and reducing any injuries due to kickback. Because of the steady feed rate, power feeders can also produce cleaner, more consistent cuts. Check the current Grizzly catalog for available power feeders.

Because of the wide range of fences and guards that can be built in the shop, explaining their construction is beyond the scope of this manual. We strongly recommend that you read shaper books, trade magazines, or get formal training to learn more about these.



SECTION 7: MAINTENANCE



General

Regular periodic maintenance on your Model G8621 Shaper ensures its optimum performance. Make a habit of inspecting your shaper each time you use it.

Check for the following conditions and repair or replace when necessary.

1. Loose mounting bolts.
2. Worn switch.
3. Worn or damaged cords and plugs.
4. Damaged V-belt.
5. Any other condition that could hamper the safe operation of this machine.



Table

Tables can be kept rust-free with regular applications of products like Boeshield® T-9. For long term storage you may want to consider products like Kleen Bore's Rust Guardit™.



Lubrication

The only parts on this machine that require periodic lubrication are the ways where the cartridge slide rides on the elevation housing and where the worm gear and bushing are located. Use a light grease or anti-seizing compound on the ways and worm gear, and give the shaft mount a shot of light oil.



V-Belt

Avoid getting grease or oil on the V-belt or pulleys. Check the V-belt, as part of a monthly inspection for proper tension and belt condition. Cracking and glazing could result in belt failure. Replace the belt if such conditions appear.



Schedule

Regularly blow out air vents with compressed air and keep the exhaust port clear. Always wear a dust mask during this operation.

For every **1 hour** of use, clean and wipe down with Boeshield™ T-9:

- Table and miter gauge slide
- Fence faces

For every **5 hours** of use, clean and oil:

- Spindle column and cartridge
- Offset adjustment mechanisms on fence
- All worm drive and other gears

Once a year, replace the V-belt.





G8621 SHAPER WIRE DIAPHR

! DANGER

Disconnect power from machine before performing electrical service. Failure to do this will result in shock hazard and death in injury. The motor starting capacitor is a stored energy device. The power disconnect switch will disconnect the motor starting capacitor. The reverse switch will discharge the capacitor. Failure to do so will lead to a severe shock hazard.

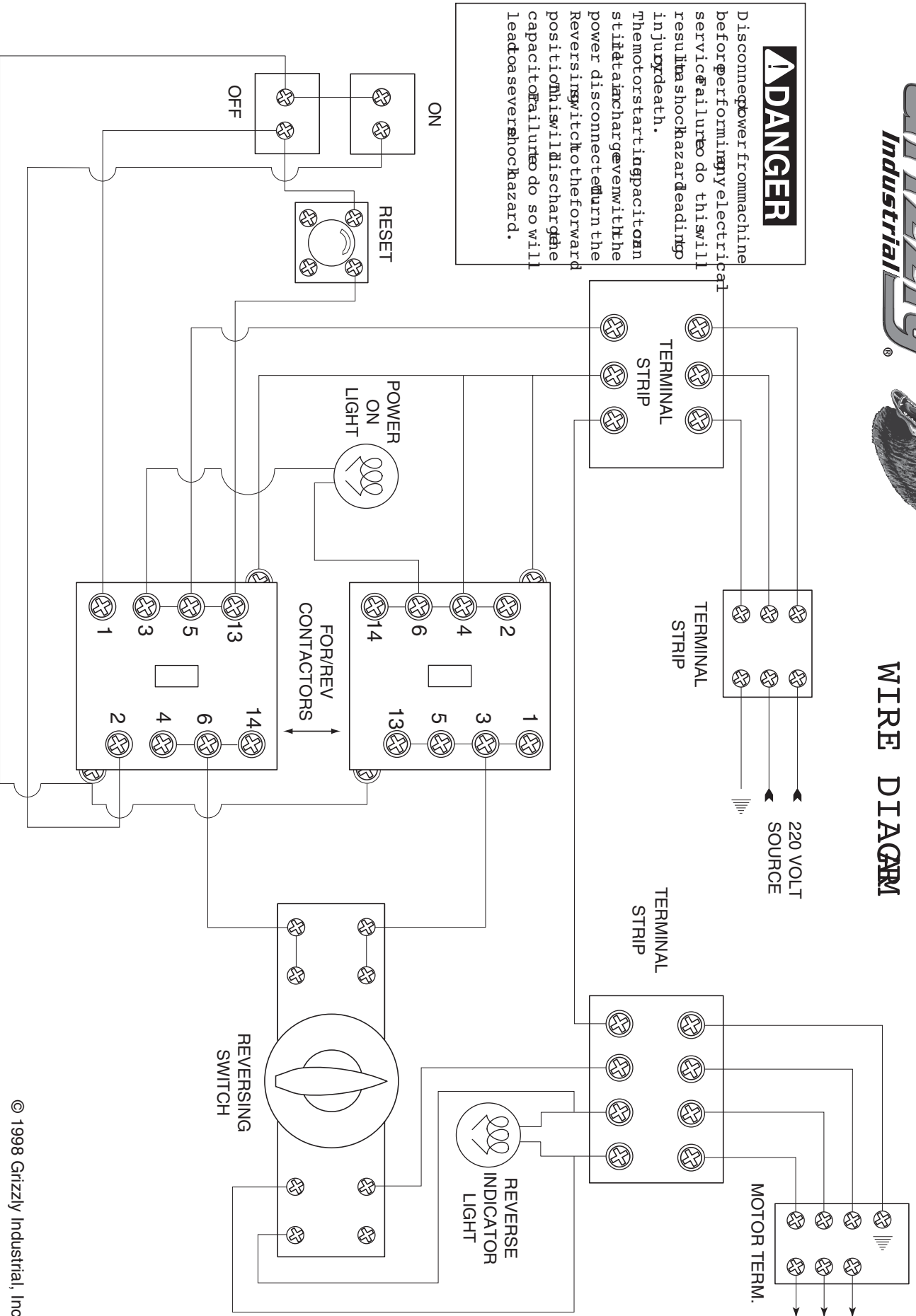

G8621 Heavy-Duty Sliding Table Shaper

SECTION 8: CLOSURE

The following pages contain general machine data, parts diagrams/lists, troubleshooting guide and Warranty/Return information for your Model G8621 Shaper.

If you need parts or help in assembling your machine, or if you need operational information, we encourage you to call our Service Department. Our trained service technicians will be glad to help you.

If you have comments dealing specifically with this manual, please write to our Bellingham, Washington location using the address in the **General Information** section. The specifications, drawings, and photographs illustrated in this manual represent the Model G8621 as supplied when the manual was prepared. However, due to Grizzly's policy of continuous improvement, changes may be made at any time with no obligation on the part of Grizzly. Whenever possible, though, we send manual updates to all owners of a particular tool or machine. Should you receive one, add the new information to this manual and keep it for reference.

We have included some important safety measures that are essential to this machine's operation. While most safety measures are generally universal, Grizzly reminds you that each workshop is different and safety rules should be considered as they apply to your specific situation.

WARNING

Operating this equipment has the potential for flying debris to cause eye injury. Always wear safety glasses or goggles when operating equipment. Everyday glasses or reading glasses only have impact resistant lenses, they are not safety glasses. Be certain the safety glasses you wear meet the appropriate standards of the American National Standards Institute (ANSI).



G8621 Heavy-Duty Sliding Table Shaper

We recommend you keep a copy of our current catalog for complete information regarding Grizzly's warranty and return policy. If you need additional technical information relating to this machine, or if you need general assistance or replacement parts, please contact the Service Department listed in the **Introduction** section.

Additional information sources are necessary to realize the full potential of this machine. Trade journals, woodworking magazines and your local library are good places to start.

WARNING

The Model G8621 was specifically designed for wood shaping operations only. **DO NOT MODIFY AND/OR USE THIS MACHINE FOR ANY OTHER PURPOSE.** Modifications or improper use of this tool will void the warranty. If you are confused about any aspect of this machine, **DO NOT** use it until all your questions have been answered, or serious personal injury may occur.

WARNING

Like all power tools, there is danger associated with the Model G8621 Shaper. Accidents are frequently caused by lack of familiarity or failure to pay attention. Use this tool with respect and caution to lessen the possibility of operator injury. If normal safety precautions are overlooked or ignored, serious personal injury may occur.





MACHINE DATA SHEET

Customer Service #: (570) 546-9663 • To Order Call: (800) 523-4777 • Fax #: (800) 438-5901

GRIZZLY MODEL G8621 HEAVY-DUTY SLIDING TABLE SHAPER

Design Type..... Floor Model

Overall Dimensions:

Fixed Table35½" x 14⁷/₈"
 Sliding Table.....35½" x 13¼"
 Height (Includes Fence)45½"
 Height from Table To Floor34³/₄"
 Length.....34³/₄"
 Width.....35½"
 Width w/ table extended56½"
 Table Fence Length39½"
 Crate Size39" L x 31" W x 44" H
 Footprint25½" x 26³/₄"
 Shipping Weight.....720 lbs.

Capacities:

Spindle Sizes¾", 1", 1¼"
 Spindle Lengths6" - 7"
 Spindle Capacity Under Nut4¼", 4⁵/₈", 5¹/₈"
 Spindle Travel.....3¼"
 Dust Port4"
 Table Counter-bore7" x 5⁵/₈"
 Max. Cutter Diameter5⁷/₈"
 Spindle Speeds3600, 5100, 8000, 10000 R.P.M.
 Sliding Table Travel21⁷/₈"

Construction:

TableGround Cast Iron
 Fence AssemblyCast Iron / Wood; Independently Micro Adjustable
 Miter FenceExtruded Aluminum
 Body AssemblyCast Iron
 CabinetFormed Steel

Motor:

TypeTEFC Capacitor-Start Induction
 Horsepower.....5 H.P.
 Phase / VoltageSingle Phase / 220 V
 Switch.....Push Button ON/OFF, Emergency Stop; Lever for Forward / Reverse
 Amps25 A
 Cycle / R.P.M.....60 Hertz / 3450 R.P.M.
 BearingsShielded & Lubricated Ball Bearings

Features:

.....Lever Actuated Stock Hold-down
Miter Angle Adjustable 60° Left to 60° Right
Miter fence adjustable stop block
4 Spring Steel Hold-down Assemblies
Fence adjustments include built-in ratchets and knob-equipped adjusters
3 Table Inserts
Spindles include spacers and nuts
Spindle height scale in inches and mm
Sliding table rides on eight shielded and lubricated ball bearings

Specifications, while deemed accurate, are not guaranteed.

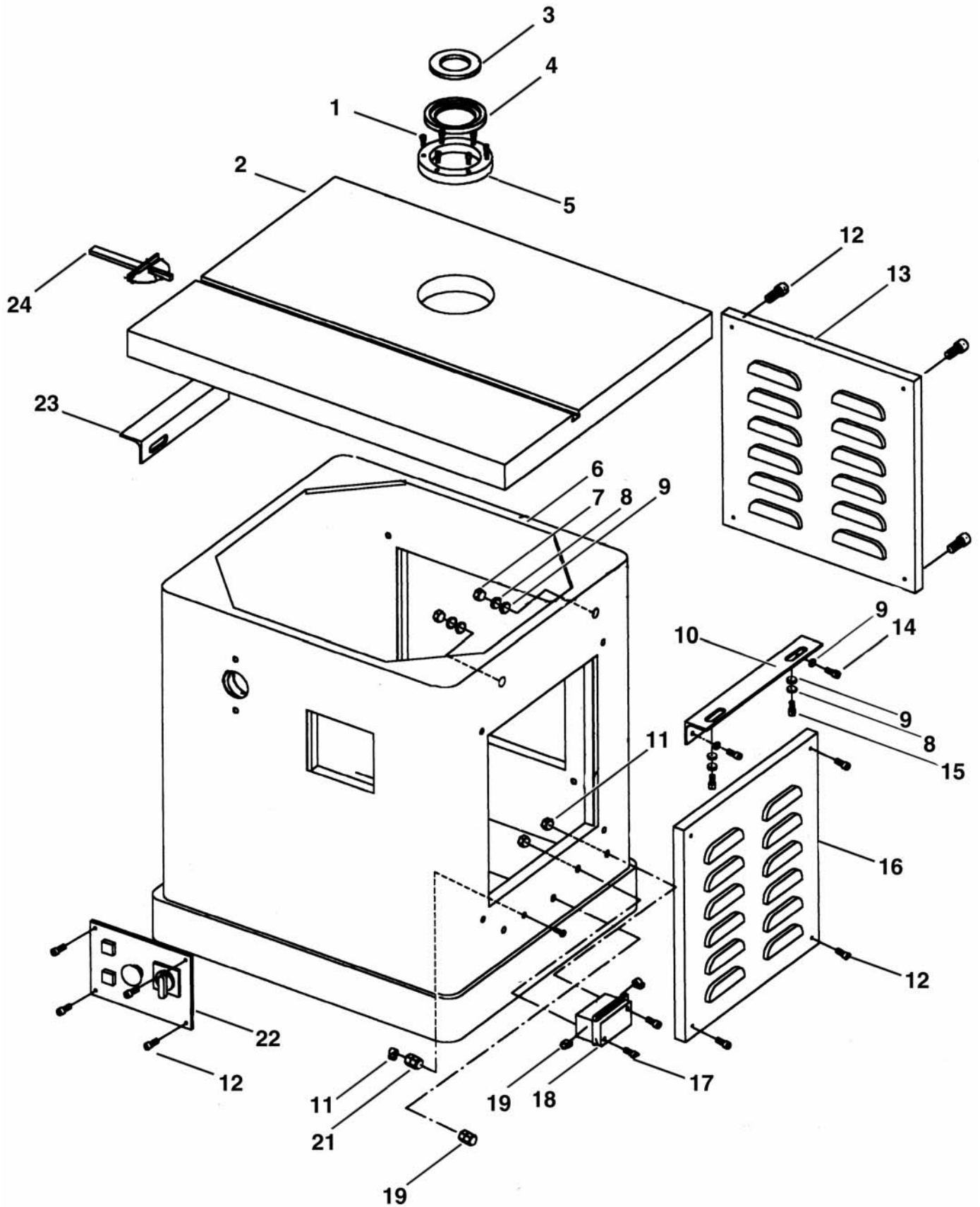

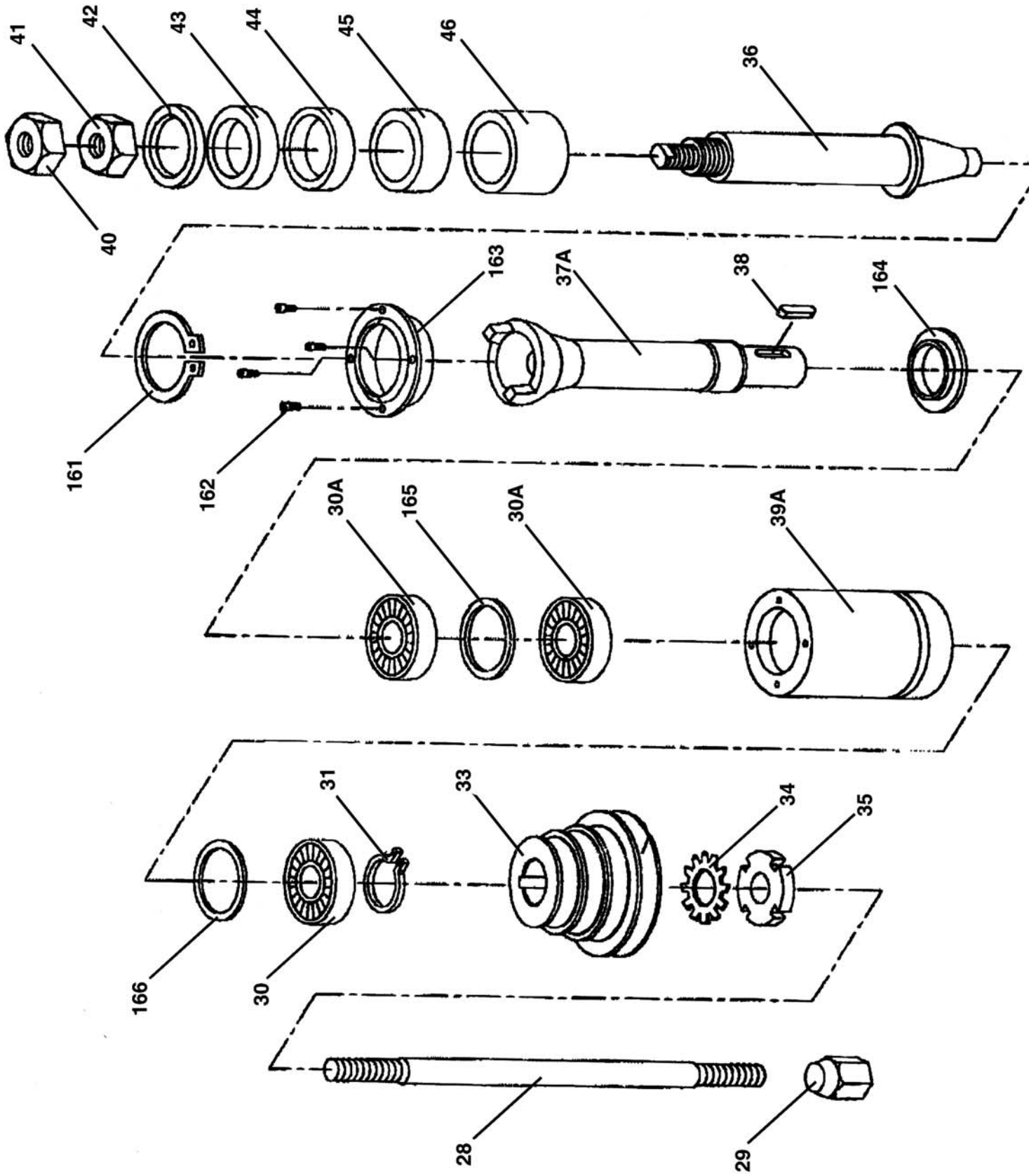

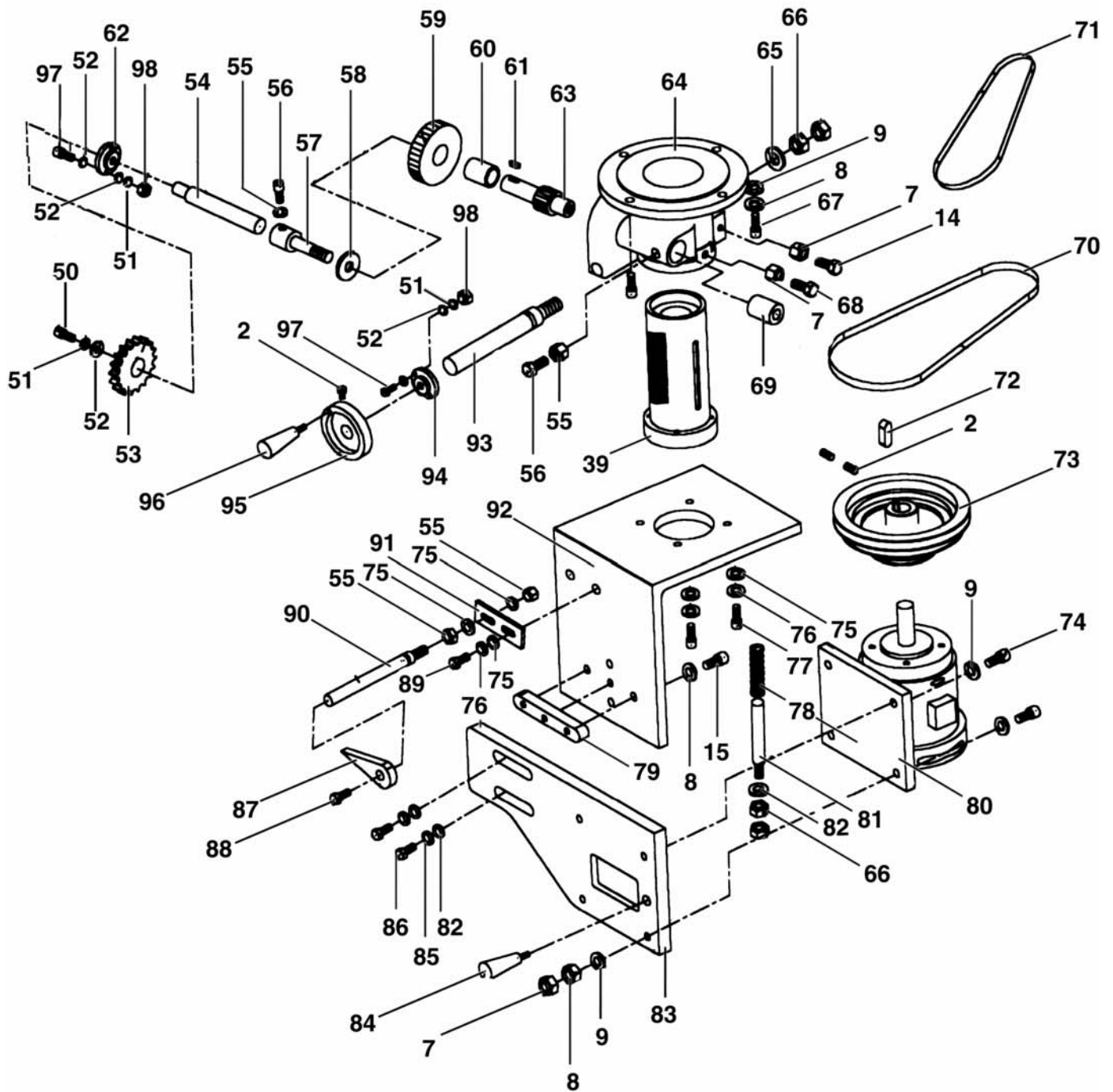

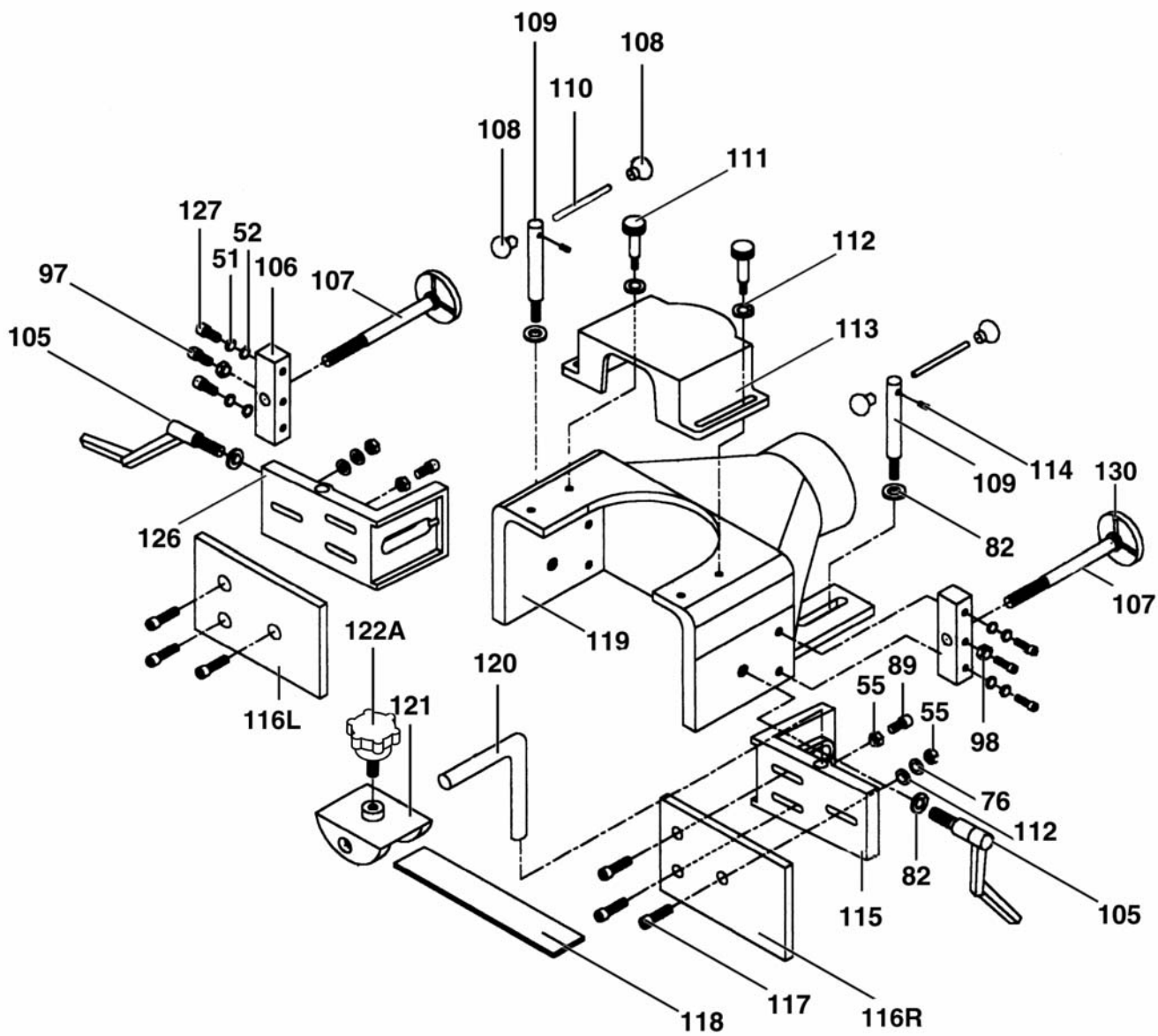

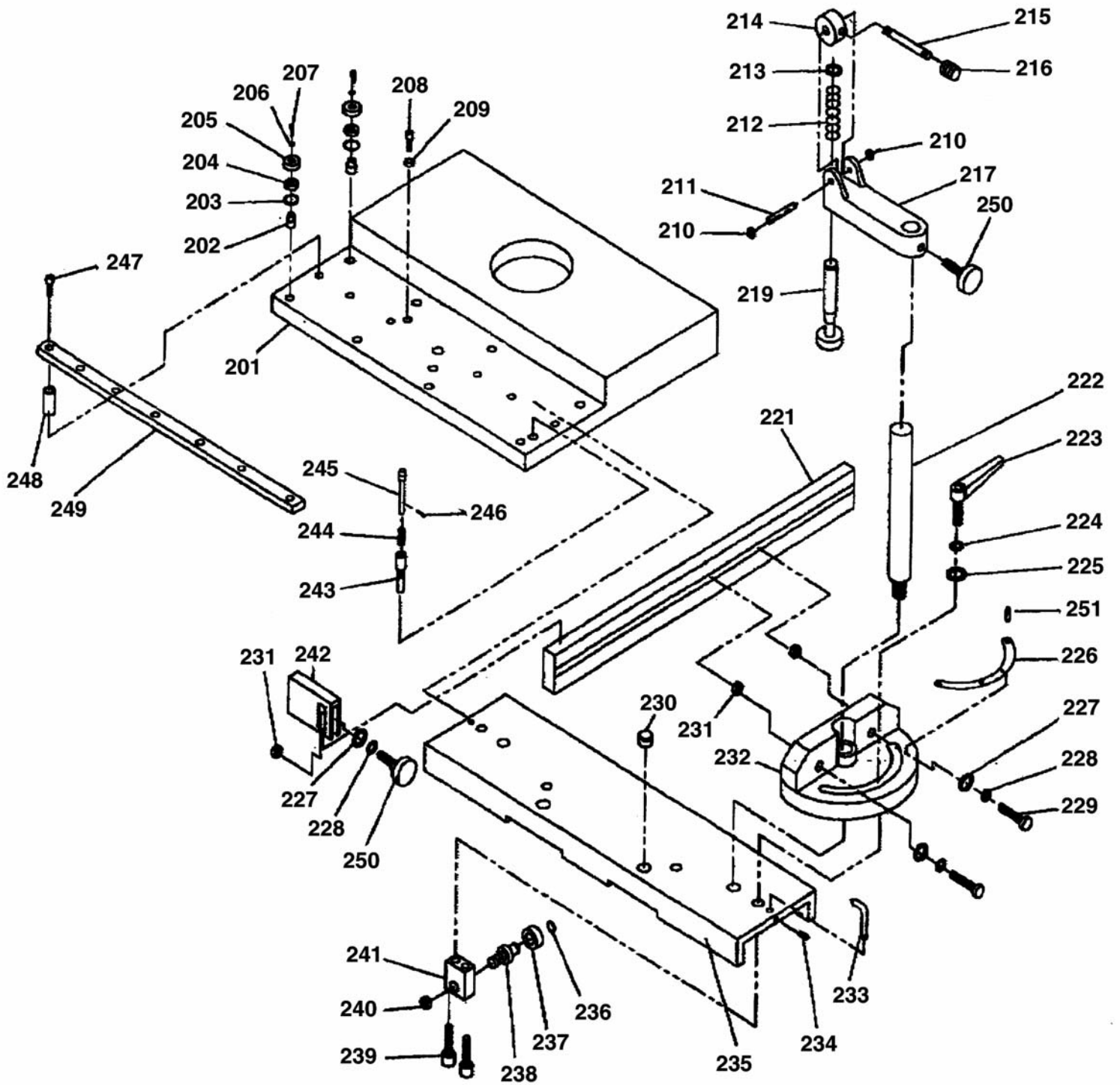

REF	PART #	DESCRIPTION
001	PSS23	SET SCREW 5/16"-24 X 5/8"
003	P5912Z003	INSERT (SMALL)
004	P5912Z004	INSERT (MID)
005	P5912Z005	INSERT (BIG)
006	P5912Z006	STAND ASSY
007	PN08	HEX NUT 3/8"-16
008	PLW04	LOCK WASHER 3/8"
009	PW02	WASHER 3/8"
010	P5912Z010	TABLE BRACE (R)
011	PN07	HEX NUT 10-24
012	PS12	PHLP HD SCR 1/4"-20 X 5/8"
013	P5912Z013	DUST DOOR
014	PB24	BOLT HEX HD 3/8"-16X1 1/4"
015	PB21	BOLT HEX HD 3/8"-16X1 3/4"
016	P5912Z016	COVER MOTOR
017	PS08	SCREW RD HD10-24 X 3/4"
018	P5912Z018	ELECTRICAL BOX ASSY
019	P5912Z019	CONNECTOR
021	P5912Z021	CONNECTOR
022	P5912Z022	ELECTRICAL BOX ASSY
023	P5912Z023	TABLE BRACE (L)
024	P5912Z024	MITER GAUGE
028	P5912Z028	BOLT
029	P5912Z029	NUT LOCK
030	P6008ZZ	BEARING 6008ZZ-K
031	P5912Z031	SNAP RING C40
032	P5912Z032	SNAP RING R80
033	P5912Z033	PULLEY SPINDLE
034	P5912Z034	WASHER
035	P5912Z035	NUT LOCK
036	P5912Z036	SPINDLE 1 1/4"
037	P5912Z037	SPINDLE CARTRIDGE
038	P5912Z038	KEY 7MM
039	P5912Z039	QUILL
040	PN09-1	SPINDLE NUT 5/8" (LH)
041	PN03	HEX NUT 3/4" (RH)
042	P5912Z042	COLLAR 1 1/4" X 1/4" 1PC
043	P5912Z043	COLLAR 1 1/4" X 3/8" 1PC
044	P5912Z044	COLLAR 1 1/4" X 1/2" 2PC
045	P5912Z045	COLLAR 1 1/4" X 3/4" 2PC
046	P5912Z046	COLLAR 1 1/4" X 1" 2PC
050	PB02	BOLT HEX HD 1/4"-20 X 5/8"
051	PLW02	LOCK WASHER 1/4"
052	PW06	WASHER 1/4"

REF	PART #	DESCRIPTION
053	P5912Z053	HANDWHEEL
054	P5912Z054	BAR LOCK
055	PN02	HEX NUT 5/16"-18
056	PB03	HEX HD BOLT 5/16"-18 X 1"
057	P5912Z057	SCREW LOCK
058	P5912Z058	WASHER GEAR
059	P5912Z059	GEAR
060	P5912Z060	COLLAR
061	P5912Z061	KEY 3MM
062	P5912Z062	BASE GEAR SHAFT
063	P5912Z063	SHAFT GEAR
064	P5912Z064	BASE SPINDLE
065	PW01	WASHER 1/2"
066	PN06	HEX NUT 1/2"
067	PSB19	CAP SCREW 3/8"-16 X 1 1/4"
068	P5912Z068	SCREW
069	P5912Z069	COLLAR
070	PVA30	V-BELT A-30 4L300
071	PVA28	V-BELT A-28 4L280
072	P5912Z072	KEY 8MM
073	P5912Z073	PULLEY MOTOR
074	PB16	HEX HD BOLT 3/8"-16X 1 1/2"
075	PW07	WASHER 5/16"
076	PLW01	LOCK WASHER 5/16"
077	PSB03	CAP SCR 5/16"-18 X 1"
078	P5912Z078	SPRING
079	P5912Z079	KEY
080	P5912Z080	MOTOR
081	P5912Z081	SHAFT SPRING
082	PW01	WASHER 1/2"
083	P5912Z083	BASE MOTOR
084	P5912Z084	KNOB
085	PLW07	LOCK WASHER 1/2"
086	PB39	HEX HD BOLT 1/2"-12X 1 1/2"
087	P5912Z087	POINTER
088	PS06	SCREW 10-24 X 3/8"
089	PB07	HEX HD BOLT 5/16"-18X 3/4"
090	P5912Z090	SHAFT GUIDE
091	P5912Z091	PLATE
092	P5912Z092	MOTOR PLATE
093	P5912Z093	SHAFT GEAR
094	P5912Z094	BASE GEAR SHAFT
095	P5912Z095	HANDWHEEL
096	P1023009	HANDLE

REF	PART #	DESCRIPTION
097	PB31	HEX HD BOLT 1/4"-20 X 1"
098	PN05	HEX NUT 1/4"-20
105	P5912Z105	RATCHET LOCK HANDLE
106	P5912Z106	BRACKET SCREW GUIDE
107	P5912Z107	SCREW GUIDE
108	P5912Z108	NUT
109	P5912Z109	SHAFT GUIDE
110	P5912Z110	BAR
111	P5912Z111	KNOB
112	PW07	WASHER 5/16"
113	P5912Z113	PLATE GUARD
114	P5912Z114	SET SCREW CUP PT 1/4"
115	P5912Z115	BRCKT ASSY FENCE RH
116	P5912Z116	FENCE WOODEN
117	P5912Z117	SCREW
118	P5912Z118	TENSION
119	P5912Z119	GUARD
120	P5912Z120	BAR
121	P5912Z121	RETAINER (L)
122A	P5912Z122A	KNOB BOLT
126	P5912Z126	BRCKT ASSY FENCE LH
127	PB26	BOLT HEX HD 1/4"-20X 1 1/2"
128	P5912Z128	RESET SWITCH
129	P5912Z129	REVERSE LIGHT
130	P5912Z130	HANDLE WHEEL
161	P5912Z161	SNAP RING C-50
162	PSB17M	CAP SCREW M4-.7 X 10
163	P5912Z163	OUTER DUST COVER
164	P5912Z164	INNER DUST COVER
165	P5912Z165	ALTERNATING RING
166	P5912Z166	WAVY RING
201	P5912Z201	TABLE
202	P5912Z202	ECCENT PULLEY SHAFT
203	PR12M	C-RING R35
204	P6202	BEARING 6202Z
205	P5912Z205	PULLEY
206	PLW01	LOCK WASHER 5/16"
207	P5912Z207	PHLP HD SCRW 5/16" X 1 1/2"
208	P5912Z208	CAP SCREW 1/2"-12 X 1 1/2"
209	PN06	HEX NUT 1/2"
210	PR39M	C-RING C8
211	P5912Z211	SHAFT
212	P5912Z212	SPRING

REF	PART #	DESCRIPTION
213	PR05M	C-RING C15
214	P5912Z214	PRESS WHEEL
215	P5912Z215	PRESS SHAFT
216	P5912Z216	PLASTIC NUT
217	P5912Z217	PRESS WOOD BASE
218	P5912Z218	HANDLE LOCK
219	P5912Z219	SPRING SHAFT & BASE
221	P5912Z221	FENCE
222	P5912Z222	PUSH SHAFT
223	P5912Z223	HANDLE LOCK
224	PLW07	LOCK WASHER 1/2"
225	PW01	WASHER 1/2"
226	P5912Z226	DEGREE TAG
227	PW02	WASHER 3/8"
228	PLW04	LOCK WASHER 3/8"
229	P5912Z229	PHLP SCREW 3/8"- X 1 1/2"
230	P5912Z230	COVER
231	P5912Z231	NUT
232	P5912Z232	GAUGE
233	P5912Z233	FINGER
234	P5912Z234	PHLP SCREW 10-24 X 1/4"
235	P5912Z235	GLIDE TABLE
236	PR01M	C RING C-10
237	P6900	BEARING 6900ZZ
238	P5912Z238	ECCENT PULLEY SHAFT
239	PSB32	CAP SCREW 1/4"-20 X 1/4"
240	P5912Z240	NUT
241	P5912Z241	BEARING BASE
242	P5912Z242	RESIST BASE
243	P5912Z243	TABLE FIX SHAFT
244	P5912Z244	SPRING
245	P5912Z245	FIX SPRING SHAFT
246	PRP02M	ROLL PIN 3 X 16MM
247	P5912Z247	CAP SCREW 1/4"-20 X 1 1/2"
248	P5912Z248	SPACER
249	P5912Z249	GUIDE ORBIT
250	P5912Z250	3/8" KNOB
251	P5912Z251	PIVOT
319	P5912Z319	HOOD
400	P5912Z400	WARNING LABEL
401	PLABEL-10	GRIZZLY NAME PLATE
402	P86211002	PULLEY LABEL
403	P5912Z403	SPEED CHANGE LABEL

WARRANTY AND RETURNS

Grizzly Industrial, Inc. warrants every product it sells for a period of **1 year** to the original purchaser from the date of purchase. This warranty does not apply to defects due directly or indirectly to misuse, abuse, negligence, accidents, repairs or alterations or lack of maintenance. This is Grizzly's sole written warranty and any and all warranties that may be implied by law, including any merchantability or fitness, for any particular purpose, are hereby limited to the duration of this written warranty. We do not warrant or represent that the merchandise complies with the provisions of any law or acts unless the manufacturer so warrants. In no event shall Grizzly's liability under this warranty exceed the purchase price paid for the product and any legal actions brought against Grizzly shall be tried in the State of Washington, County of Whatcom.

We shall in no event be liable for death, injuries to persons or property or for incidental, contingent, special, or consequential damages arising from the use of our products.

To take advantage of this warranty, contact us by mail or phone and give us all the details. We will then issue you a "Return Number," which must be clearly posted on the outside as well as the inside of the carton. We will not accept any item without this number. Proof of purchase must accompany the merchandise.

The manufacturers reserve the right to change specifications at any time because they constantly strive to achieve better quality equipment. We make every effort to ensure that our products meet high quality and durability standards and we hope you never need to use this warranty.

Please feel free to write or call us if you have any questions about the machine or the manual.

Thank you again for your business and continued support. We hope to serve you again soon.

WARRANTY CARD

Name _____
Street _____
City _____ State _____ Zip _____
Phone Number _____ E-Mail _____ FAX _____
MODEL #G8621 Heavy-Duty Sliding Table Shaper Order _____

The following information is given on a voluntary basis. It will be used for marketing purposes to help us develop better products and services. Of course, all information is strictly confidential.

- How did you learn about us?
 Advertisement Friend
 Catalog World Wide Web
 Other _____
- Which of the following magazines do you subscribe to.
 American Woodworker Practical Homeowner
 Cabinetmaker Shop Notes
 Family Handyman Today's Homeowner
 Fine Homebuilding WOOD
 Fine Woodworking Wooden Boat
 Home Handyman Woodshop News
 Journal of Light Construction Woodsmith
 Old House Journal Woodwork
 Popular Mechanics Woodworker
 Popular Science Woodworker's Journal
 Popular Woodworking Workbench
 Other _____
- Which of the following woodworking/remodeling shows do you watch?
 Backyard America The New Yankee Workshop
 Home Time This Old House
 The American Woodworker Woodwright's Shop
 Other _____
- What is your annual household income?
 \$20,000-\$29,999 \$60,000-\$69,999
 \$30,000-\$39,999 \$70,000-\$79,999
 \$40,000-\$49,999 \$80,000-\$89,999
 \$50,000-\$59,999 \$90,000 +
- What is your age group?
 20-29 50-59
 30-39 60-69
 40-49 70 +
- How long have you been a woodworker?
 0 - 2 Years 8 - 20 Years
 2 - 8 Years 20+ Years
- How would you rank your woodworking skills?
 Simple Advanced
 Intermediate Master Craftsman
- What stationary woodworking tools do you own? Check all that apply.
 Air Compressor Panel Saw
 Band Saw Planer
 Drill Press Power Feeder
 Drum Sander Radial Arm Saw
 Dust Collector Shaper
 Horizontal Boring Machine Spindle Sander
 Jointer Table Saw
 Lathe Vacuum Veneer Press
 Mortiser Wide Belt Sander
 Other _____
- How many of your woodworking machines are Grizzly? _____
- Which benchtop tools do you own? Check all that apply.
 1" x 42" Belt Sander 6" - 8" Grinder
 5" - 8" Drill Press Mini Lathe
 8" Table Saw 10" - 12" Thickness Planer
 8" - 10" Bandsaw Scroll Saw
 Disc/Belt Sander Spindle/Belt Sander
 Mini Jointer
 Other _____
- How many of the machines checked above are Grizzly? _____
- Which portable/hand held power tools do you own? Check all that apply.
 Belt Sander Orbital Sander
 Biscuit Joiner Palm Sander
 Circular Saw Portable Planer
 Detail Sander Saber Saw
 Drill/Driver Reciprocating Saw
 Miter Saw Router
 Other _____
- What machines/supplies would you like Grizzly Industrial to carry?
 12" Table Saw Radial Arm Saw
 12" Jointer Panel Saw
 Combination Planer/Joiner Brass Hardware
 Paint & Finishing Supplies Lumber
 Contractor's Supplies
 Other _____
- What new accessories would you like Grizzly Industrial to carry?
 Builders Hardware Hand Tools
 Fasteners Wood Components
 Other _____
- What other companies do you purchase your tools and supplies from?

- Do you think your purchase represents good value?
 Yes No
- Would you recommend Grizzly Imports to a friend?
 Yes No
- Would you allow us to use your name as a reference for Grizzly customers in your area? **Note: We never use names more than three times.**
 Yes No
- Comments: _____

CUT ALONG DOTTED LINE

FOLD ALONG DOTTED LINE



Place
Stamp
Here



GRIZZLY INDUSTRIAL, INC.
P.O. BOX 2069
BELLINGHAM, WA 98227-2069



FOLD ALONG DOTTED LINE

Send a Grizzly Catalog to a friend:

Name _____
Street _____
City _____ State _____ Zip _____

TAPE ALONG EDGES--PLEASE DO NOT STAPLE

grizzly.com

TOOL WEBSITE

Buy Direct and Save with Grizzly® – Trusted, Proven and a Great Value!

Visit Our Website Today And Discover Why
Grizzly® Is The Industry Leader!

- 
- 
- 

B

A

B

G

1-800-523-4777

